

OPEX®
OMATION®
SERIES 410

February 2024

Manual #9286910OM-EN

Revision 24-01

Original Instructions

Operator Manual



OMATIION® Series 410™ Envelopener®



WARNING

Read this manual thoroughly before attempting to operate or service this equipment. Keep a current copy for your reference.

© 2019, 2021, 2024 OPEX® Corporation

All rights reserved. This publication is made available solely for use by the OPEX Service Organization. The information contained herein is proprietary, confidential and copyrighted by OPEX® Corporation. Copying, duplicating, selling, or otherwise distributing any part of this publication or the information contained herein without the express written consent of OPEX® Corporation is strictly forbidden.

Contacting OPEX

For technical support:

OPEX Technical Support
1224 N Church Street
Moorestown, NJ 08057 USA

Americas: 1 800.673.9288 -OR- 856.727.1950

EMEA: +1 800.673.9288

Australia: +1 800.945247

Service@opex.com

Please have the model name and serial number of the product ready (see [“Equipment Model/Serial Number Locations” on page 29](#)).

For other inquiries:

OPEX[®] Corporation
305 Commerce Dr.
Moorestown, NJ 08057-4234 USA
Tel: +1 856.727.1100
Fax: +1 856.727.1955
<https://www.opex.com/>

If you find errors, inaccuracies, or any other issues or concerns with this document, please contact the OPEX Technical Writers via email at: GroupDMATechWriters@opex.com

For help with opexservice.com website-related issues, please contact the OPEX Web Developers via email at: dshelp@opex.com

0.1. CE Declaration of Conformity

Declaration of Conformity Australia: AU

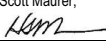
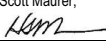
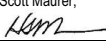
		EU Declaration of Conformity OM410 This declaration of conformity is issued under the sole responsibility of the manufacturer.																		
1.0	Manufacturer	<table border="1"> <tr> <td>NAME</td> <td>OPEX Corporation</td> </tr> <tr> <td>ADDRESS</td> <td>835 Lancer Drive, Moorestown, NJ 08057, USA</td> </tr> </table>	NAME	OPEX Corporation	ADDRESS	835 Lancer Drive, Moorestown, NJ 08057, USA														
NAME	OPEX Corporation																			
ADDRESS	835 Lancer Drive, Moorestown, NJ 08057, USA																			
2.0	Technical File	Technical documentation is compiled in accordance with Part B of Annex VII of the machinery directive. This documentation is available on a reasoned request by appropriate national authority to our authorized representative: <table border="1"> <tr> <td>NAME</td> <td>OPEX Business Machines Pty Ltd</td> </tr> <tr> <td>ADDRESS</td> <td>Level 12, 225 George Street Sydney, NSW 2000 Australia</td> </tr> </table>	NAME	OPEX Business Machines Pty Ltd	ADDRESS	Level 12, 225 George Street Sydney, NSW 2000 Australia														
NAME	OPEX Business Machines Pty Ltd																			
ADDRESS	Level 12, 225 George Street Sydney, NSW 2000 Australia																			
3.0	Description and identification	<table border="1"> <tr> <td>Description</td> <td>Envelope Opener</td> </tr> <tr> <td>Model</td> <td>OM410</td> </tr> <tr> <td>Serial Number</td> <td></td> </tr> <tr> <td>Year Manufactured</td> <td>From 2019</td> </tr> </table>	Description	Envelope Opener	Model	OM410	Serial Number		Year Manufactured	From 2019										
Description	Envelope Opener																			
Model	OM410																			
Serial Number																				
Year Manufactured	From 2019																			
4.0	Directives	<table border="1"> <tr> <td>2014/35/EU</td> <td>Low Voltage Directive</td> </tr> <tr> <td>2014/30/EU</td> <td>Electromagnetic Compatibility Directive</td> </tr> <tr> <td>2011/65/EU</td> <td>RoHS 2 Directive</td> </tr> <tr> <td>2015/863/EU</td> <td>RoHS 3 amendment</td> </tr> </table>	2014/35/EU	Low Voltage Directive	2014/30/EU	Electromagnetic Compatibility Directive	2011/65/EU	RoHS 2 Directive	2015/863/EU	RoHS 3 amendment										
2014/35/EU	Low Voltage Directive																			
2014/30/EU	Electromagnetic Compatibility Directive																			
2011/65/EU	RoHS 2 Directive																			
2015/863/EU	RoHS 3 amendment																			
5.0	Certified Body	<table border="1"> <tr> <td></td> <td>Intertek Testing Services NA, Inc. 70 Codman Hill Rd. Boxborough MA 01719 USA</td> </tr> </table>		Intertek Testing Services NA, Inc. 70 Codman Hill Rd. Boxborough MA 01719 USA																
	Intertek Testing Services NA, Inc. 70 Codman Hill Rd. Boxborough MA 01719 USA																			
6.0	Harmonized Standards used	<table border="1"> <tr> <td>IEC 62368-1:2014Ed.2+C1</td> <td>Audio/video, information and communication technology equipment Part 1: Safety requirements</td> </tr> <tr> <td>IEC 61000-3-2:2014</td> <td>Harmonics</td> </tr> <tr> <td>IEC 61000-3-3:2013</td> <td>Flicker</td> </tr> <tr> <td>IEC 61000-4-2:2008</td> <td>Electro-Static Discharge Immunity Test</td> </tr> <tr> <td>IEC 61000-4-3:2006, IEC 61000-4-3:2006/AMD1:2007 IEC 610004-3:2006/AMD2:2010</td> <td>Radiated, Radio-Frequency, Electromagnetic Immunity</td> </tr> <tr> <td>IEC 61000-4-4:2012</td> <td>Electrical Fast Transient/Burst Immunity Test</td> </tr> <tr> <td>IEC 61000-4-5:2014</td> <td>Immunity to Surges</td> </tr> <tr> <td>IEC 61000-4-6:2013</td> <td>Conducted, Radio-Frequency, Electromagnetic Immunity Test</td> </tr> <tr> <td>IEC 61000-4-11:2004</td> <td>Voltage Dips/Interruptions Immunity Test</td> </tr> </table>	IEC 62368-1:2014Ed.2+C1	Audio/video, information and communication technology equipment Part 1: Safety requirements	IEC 61000-3-2:2014	Harmonics	IEC 61000-3-3:2013	Flicker	IEC 61000-4-2:2008	Electro-Static Discharge Immunity Test	IEC 61000-4-3:2006, IEC 61000-4-3:2006/AMD1:2007 IEC 610004-3:2006/AMD2:2010	Radiated, Radio-Frequency, Electromagnetic Immunity	IEC 61000-4-4:2012	Electrical Fast Transient/Burst Immunity Test	IEC 61000-4-5:2014	Immunity to Surges	IEC 61000-4-6:2013	Conducted, Radio-Frequency, Electromagnetic Immunity Test	IEC 61000-4-11:2004	Voltage Dips/Interruptions Immunity Test
IEC 62368-1:2014Ed.2+C1	Audio/video, information and communication technology equipment Part 1: Safety requirements																			
IEC 61000-3-2:2014	Harmonics																			
IEC 61000-3-3:2013	Flicker																			
IEC 61000-4-2:2008	Electro-Static Discharge Immunity Test																			
IEC 61000-4-3:2006, IEC 61000-4-3:2006/AMD1:2007 IEC 610004-3:2006/AMD2:2010	Radiated, Radio-Frequency, Electromagnetic Immunity																			
IEC 61000-4-4:2012	Electrical Fast Transient/Burst Immunity Test																			
IEC 61000-4-5:2014	Immunity to Surges																			
IEC 61000-4-6:2013	Conducted, Radio-Frequency, Electromagnetic Immunity Test																			
IEC 61000-4-11:2004	Voltage Dips/Interruptions Immunity Test																			
7.0	Technical Standards used	<table border="1"> <tr> <td>UL 62368-1:2014 Ed.2</td> <td>Audio/Video, Information And Communication Technology Equipment - Part 1: Safety Requirements</td> </tr> <tr> <td>CSA C22.2#62368-1:2014 Ed.2</td> <td>Audio/Video, Information And Communication Technology Equipment - Part 1: Safety Requirements</td> </tr> <tr> <td>CISPR 32 Ed 2.0:2015</td> <td>Radiated Emissions, AC Mains Conducted Emissions Electromagnetic Compatibility Of Multimedia Equipment - Emission Requirements</td> </tr> <tr> <td>FCC 47CFR PT 15 Sub Part B: April 16, 2019</td> <td>Radiated Emissions, AC Mains Conducted Emissions Unintentional Radiator</td> </tr> <tr> <td>ISO 7779 Issued:1999/08/01</td> <td>Acoustics - Measurement of Airborne Noise Emitted by Information Technology and Telecommunications Equipment-Second Edition; Amendment 1: 3/01/2003</td> </tr> </table>	UL 62368-1:2014 Ed.2	Audio/Video, Information And Communication Technology Equipment - Part 1: Safety Requirements	CSA C22.2#62368-1:2014 Ed.2	Audio/Video, Information And Communication Technology Equipment - Part 1: Safety Requirements	CISPR 32 Ed 2.0:2015	Radiated Emissions, AC Mains Conducted Emissions Electromagnetic Compatibility Of Multimedia Equipment - Emission Requirements	FCC 47CFR PT 15 Sub Part B: April 16, 2019	Radiated Emissions, AC Mains Conducted Emissions Unintentional Radiator	ISO 7779 Issued:1999/08/01	Acoustics - Measurement of Airborne Noise Emitted by Information Technology and Telecommunications Equipment-Second Edition; Amendment 1: 3/01/2003								
UL 62368-1:2014 Ed.2	Audio/Video, Information And Communication Technology Equipment - Part 1: Safety Requirements																			
CSA C22.2#62368-1:2014 Ed.2	Audio/Video, Information And Communication Technology Equipment - Part 1: Safety Requirements																			
CISPR 32 Ed 2.0:2015	Radiated Emissions, AC Mains Conducted Emissions Electromagnetic Compatibility Of Multimedia Equipment - Emission Requirements																			
FCC 47CFR PT 15 Sub Part B: April 16, 2019	Radiated Emissions, AC Mains Conducted Emissions Unintentional Radiator																			
ISO 7779 Issued:1999/08/01	Acoustics - Measurement of Airborne Noise Emitted by Information Technology and Telecommunications Equipment-Second Edition; Amendment 1: 3/01/2003																			
8.0	Approval	I, the undersigned, hereby declare that the equipment specified above conforms to the above Directive(s) and Standard(s). <table border="1"> <tr> <td>Place of issue</td> <td>Moorestown, NJ, USA</td> </tr> <tr> <td>Date of issue</td> <td>Apr 24, 2019</td> </tr> <tr> <td>Authorized</td> <td>Scott Maurer, </td> </tr> <tr> <td>Title</td> <td>President, International Division</td> </tr> </table>	Place of issue	Moorestown, NJ, USA	Date of issue	Apr 24, 2019	Authorized	Scott Maurer, 	Title	President, International Division										
Place of issue	Moorestown, NJ, USA																			
Date of issue	Apr 24, 2019																			
Authorized	Scott Maurer, 																			
Title	President, International Division																			
Drawing: 92801xx-DoC-AU		Revision: 0.1																		

Declaration of Conformity France: FR



EU Declaration of Conformity OM410

This declaration of conformity is issued under the sole responsibility of the manufacturer.

1.0	Manufacturer	NAME	OPEX Corporation
		ADDRESS	835 Lancer Drive, Moorestown, NJ 08057, USA
2.0	Technical File	Technical documentation is compiled in accordance with Part B of Annex VII of the machinery directive. This documentation is available on a reasoned request by appropriate national authority to our authorized representative:	
		NAME	OPEX Corporation
		ADDRESS	Les Fjords - Bâtiment Vega 19, avenue de Norvège ZA de Courtaboeuf 91140 Villebon-sur-Yvette, France
3.0	Description and identification	Description	Envelope Opener
		Model	OM410
		Serial Number	
		Year Manufactured	From 2019
4.0	Directives	2014/35/EU	Low Voltage Directive
		2014/30/EU	Electromagnetic Compatibility Directive
		2011/65/EU	RoHS 2 Directive
		2015/863/EU	RoHS 3 amendment
5.0	Certified Body	Intertek Testing Services NA, Inc. 70 Codman Hill Rd. Boxborough MA 01719 USA	
6.0	Harmonized Standards used	IEC 62368-1:2014Ed.2+C1	Audio/video, information and communication technology equipment Part 1: Safety requirements
		IEC 61000-3-2:2014	Harmonics
		IEC 61000-3-3:2013	Flicker
		IEC 61000-4-2:2008	Electro-Static Discharge Immunity Test
		IEC 61000-4-3:2006, IEC 61000-4-3:2006/AMD1:2007 IEC 610004-3:2006/AMD2:2010	Radiated, Radio-Frequency, Electromagnetic Immunity
		IEC 61000-4-4:2012	Electrical Fast Transient/Burst Immunity Test
		IEC 61000-4-5:2014	Immunity to Surges
		IEC 61000-4-6:2013	Conducted, Radio-Frequency, Electromagnetic Immunity Test
		IEC 61000-4-11:2004	Voltage Dips/Interruptions Immunity Test
7.0	Technical Standards used	UL 62368-1:2014 Ed.2	Audio/Video, Information And Communication Technology Equipment - Part 1: Safety Requirements
		CSA C22.2#62368-1:2014 Ed.2	Audio/Video, Information And Communication Technology Equipment - Part 1: Safety Requirements
		CISPR 32 Ed 2.0:2015	Radiated Emissions, AC Mains Conducted Emissions Electromagnetic Compatibility Of Multimedia Equipment - Emission Requirements
		FCC 47CFR PT 15 Sub Part B: April 16, 2019	Radiated Emissions, AC Mains Conducted Emissions Unintentional Radiator
		ISO 7779 Issued:1999/08/01	Acoustics - Measurement of Airborne Noise Emitted by Information Technology and Telecommunications Equipment-Second Edition; Amendment 1: 3/01/2003
8.0	Approval	I, the undersigned, hereby declare that the equipment specified above conforms to the above Directive(s) and Standard(s).	
		Place of issue	Moorestown, NJ, USA
		Date of issue	Apr 24, 2019
		Authorized	Scott Maurer,
		Title	President, International Division

Drawing: 92801xx-DoC-FR

Revision: 0.1

Declaration of Conformity Germany: GR



EU Declaration of Conformity OM410

This declaration of conformity is issued under the sole responsibility of the manufacturer.

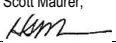
1.0	Manufacturer	NAME	OPEX Corporation
		ADDRESS	835 Lancer Drive, Moorestown, NJ 08057, USA
2.0	Technical File	Technical documentation is compiled in accordance with Part B of Annex VII of the machinery directive. This documentation is available on a reasoned request by appropriate national authority to our authorized representative:	
		NAME	OPEX Corporation
		ADDRESS	Auf der Lug 8 71726 Benningen am Neckar Germany
3.0	Description and identification	Description	Envelope Opener
		Model	OM410
		Serial Number	
		Year Manufactured	From 2019
4.0	Directives	2014/35/EU	Low Voltage Directive
		2014/30/EU	Electromagnetic Compatibility Directive
		2011/65/EU	RoHS 2 Directive
		2015/863/EU	RoHS 3 amendment
5.0	Certified Body	Intertek Testing Services NA, Inc. 70 Codman Hill Rd. Boxborough MA 01719 USA	
6.0	Harmonized Standards used	IEC 62368-1:2014Ed.2+C1	Audio/video, information and communication technology equipment Part 1: Safety requirements
		IEC 61000-3-2:2014	Harmonics
		IEC 61000-3-3:2013	Flicker
		IEC 61000-4-2:2008	Electro-Static Discharge Immunity Test
		IEC 61000-4-3:2006, IEC 61000-4-3:2006/AMD1:2007 IEC 610004-3:2006/AMD2:2010	Radiated, Radio-Frequency, Electromagnetic Immunity
		IEC 61000-4-4:2012	Electrical Fast Transient/Burst Immunity Test
		IEC 61000-4-5:2014	Immunity to Surges
		IEC 61000-4-6:2013	Conducted, Radio-Frequency, Electromagnetic Immunity Test
		IEC 61000-4-11:2004	Voltage Dips/Interruptions Immunity Test
7.0	Technical Standards used	UL 62368-1:2014 Ed.2	Audio/Video, Information And Communication Technology Equipment - Part 1: Safety Requirements
		CSA C22.2#62368-1:2014 Ed.2	Audio/Video, Information And Communication Technology Equipment - Part 1: Safety Requirements
		CISPR 32 Ed 2.0:2015	Radiated Emissions, AC Mains Conducted Emissions Electromagnetic Compatibility Of Multimedia Equipment - Emission Requirements
		FCC 47CFR PT 15 Sub Part B: April 16, 2019	Radiated Emissions, AC Mains Conducted Emissions Unintentional Radiator
		ISO 7779 Issued:1999/08/01	Acoustics - Measurement of Airborne Noise Emitted by Information Technology and Telecommunications Equipment-Second Edition; Amendment 1: 3/01/2003
8.0	Approval	I, the undersigned, hereby declare that the equipment specified above conforms to the above Directive(s) and Standard(s).	
		Place of issue	Moorestown, NJ, USA
		Date of issue	Apr 24, 2019
		Authorized	Scott Maurer, 
		Title	President, International Division

Drawing: 92801xx-DoC-GR

Revision: 0.1

Declaration of Conformity Republic of Ireland: IR



EU Declaration of Conformity OM410

This declaration of conformity is issued under the sole responsibility of the manufacturer.

1.0	Manufacturer	NAME	OPEX Corporation
		ADDRESS	835 Lancer Drive, Moorestown, NJ 08057, USA
2.0	Technical File	Technical documentation is compiled in accordance with Part B of Annex VII of the machinery directive. This documentation is available on a reasoned request by appropriate national authority to our authorized representative:	
		NAME	OPEX Business Machines GmbH
		ADDRESS	104 Lower Baggot Street Dublin 2 Republic of Ireland
3.0	Description and identification	Description	Envelope Opener
		Model	OM410
		Serial Number	
		Year Manufactured	From 2019
4.0	Directives	2014/35/EU	Low Voltage Directive
		2014/30/EU	Electromagnetic Compatibility Directive
		2011/65/EU	RoHS 2 Directive
		2015/863/EU	RoHS 3 amendment
5.0	Certified Body	Intertek Testing Services NA, Inc. 70 Codman Hill Rd. Boxborough MA 01719 USA	
6.0	Harmonized Standards used	IEC 62368-1:2014Ed.2+C1	Audio/video, information and communication technology equipment Part 1: Safety requirements
		IEC 61000-3-2:2014	Harmonics
		IEC 61000-3-3:2013	Flicker
		IEC 61000-4-2:2008	Electro-Static Discharge Immunity Test
		IEC 61000-4-3:2006, IEC 61000-4-3:2006/AMD1:2007 IEC 610004-3:2006/AMD2:2010	Radiated, Radio-Frequency, Electromagnetic Immunity
		IEC 61000-4-4:2012	Electrical Fast Transient/Burst Immunity Test
		IEC 61000-4-5:2014	Immunity to Surges
		IEC 61000-4-6:2013	Conducted, Radio-Frequency, Electromagnetic Immunity Test
		IEC 61000-4-11:2004	Voltage Dips/Interruptions Immunity Test
7.0	Technical Standards used	UL 62368-1:2014 Ed.2	Audio/Video, Information And Communication Technology Equipment - Part 1: Safety Requirements
		CSA C22.2#62368-1:2014 Ed.2	Audio/Video, Information And Communication Technology Equipment - Part 1: Safety Requirements
		CISPR 32 Ed 2.0:2015	Radiated Emissions, AC Mains Conducted Emissions Electromagnetic Compatibility Of Multimedia Equipment - Emission Requirements
		FCC 47CFR PT 15 Sub Part B: April 16, 2019	Radiated Emissions, AC Mains Conducted Emissions Unintentional Radiator
		ISO 7779 Issued:1999/08/01	Acoustics - Measurement of Airborne Noise Emitted by Information Technology and Telecommunications Equipment-Second Edition; Amendment 1: 3/01/2003
8.0	Approval	I, the undersigned, hereby declare that the equipment specified above conforms to the above Directive(s) and Standard(s).	
		Place of issue	Moorestown, NJ, USA
		Date of issue	Apr 24, 2019
		Authorized	Scott Maurer,
		Title	President, International Division

Drawing: 92801xx-DoC-IR

Revision: 0.1

Declaration of Conformity Switzerland: SW



EU Declaration of Conformity OM410

This declaration of conformity is issued under the sole responsibility of the manufacturer.

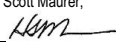
1.0	Manufacturer	NAME	OPEX Corporation
		ADDRESS	835 Lancer Drive, Moorestown, NJ 08057, USA
2.0	Technical File	Technical documentation is compiled in accordance with Part B of Annex VII of the machinery directive. This documentation is available on a reasoned request by appropriate national authority to our authorized representative:	
		NAME	OPEX Business Machines GmbH
		ADDRESS	Pilatusstrasse 41 6003 Luzern Switzerland
3.0	Description and identification	Description	Envelope Opener
		Model	OM410
		Serial Number	
		Year Manufactured	From 2019
4.0	Directives	2014/35/EU	Low Voltage Directive
		2014/30/EU	Electromagnetic Compatibility Directive
		2011/65/EU	RoHS 2 Directive
		2015/863/EU	RoHS 3 amendment
5.0	Certified Body	Intertek Testing Services NA, Inc. 70 Codman Hill Rd. Boxborough MA 01719 USA	
6.0	Harmonized Standards used	IEC 62368-1:2014Ed.2+C1	Audio/video, information and communication technology equipment Part 1: Safety requirements
		IEC 61000-3-2:2014	Harmonics
		IEC 61000-3-3:2013	Flicker
		IEC 61000-4-2:2008	Electro-Static Discharge Immunity Test
		IEC 61000-4-3:2006, IEC 61000-4-3:2006/AMD1:2007 IEC 610004-3:2006/AMD2:2010	Radiated, Radio-Frequency, Electromagnetic Immunity
		IEC 61000-4-4:2012	Electrical Fast Transient/Burst Immunity Test
		IEC 61000-4-5:2014	Immunity to Surges
		IEC 61000-4-6:2013	Conducted, Radio-Frequency, Electromagnetic Immunity Test
		IEC 61000-4-11:2004	Voltage Dips/Interruptions Immunity Test
7.0	Technical Standards used	UL 62368-1:2014 Ed.2	Audio/Video, Information And Communication Technology Equipment - Part 1: Safety Requirements
		CSA C22.2#62368-1:2014 Ed.2	Audio/Video, Information And Communication Technology Equipment - Part 1: Safety Requirements
		CISPR 32 Ed 2.0:2015	Radiated Emissions, AC Mains Conducted Emissions Electromagnetic Compatibility Of Multimedia Equipment - Emission Requirements
		FCC 47CFR PT 15 Sub Part B: April 16, 2019	Radiated Emissions, AC Mains Conducted Emissions Unintentional Radiator
		ISO 7779 Issued:1999/08/01	Acoustics - Measurement of Airborne Noise Emitted by Information Technology and Telecommunications Equipment-Second Edition; Amendment 1: 3/01/2003
8.0	Approval	I, the undersigned, hereby declare that the equipment specified above conforms to the above Directive(s) and Standard(s).	
		Place of issue	Moorestown, NJ, USA
		Date of issue	Apr 24, 2019
		Authorized	Scott Maurer, 
		Title	President, International Division

Drawing: 92801xx-DoC-SW

Revision: 0.1

Declaration of Conformity United Kingdom: UK



EU Declaration of Conformity OM410

This declaration of conformity is issued under the sole responsibility of the manufacturer.

1.0	Manufacturer	NAME	OPEX Corporation
		ADDRESS	835 Lancer Drive, Moorestown, NJ 08057, USA
2.0	Technical File	Technical documentation is compiled in accordance with Part B of Annex VII of the machinery directive. This documentation is available on a reasoned request by appropriate national authority to our authorized representative:	
		NAME	OPEX Business Machines GmbH
		ADDRESS	29/32 Queensbrook Bolton Technology Exchange Spa Road Bolton, BL1 4AY United Kingdom
3.0	Description and identification	Description	Envelope Opener
		Model	OM410
		Serial Number	
		Year Manufactured	From 2019
4.0	Directives	2014/35/EU	Low Voltage Directive
		2014/30/EU	Electromagnetic Compatibility Directive
		2011/65/EU	RoHS 2 Directive
		2015/863/EU	RoHS 3 amendment
5.0	Certified Body	Intertek Testing Services NA, Inc. 70 Codman Hill Rd. Boxborough MA 01719 USA	
6.0	Harmonized Standards used	IEC 62368-1:2014Ed.2+C1	Audio/video, information and communication technology equipment Part 1: Safety requirements
		IEC 61000-3-2:2014	Harmonics
		IEC 61000-3-3:2013	Flicker
		IEC 61000-4-2:2008	Electro-Static Discharge Immunity Test
		IEC 61000-4-3:2006, IEC 61000-4-3:2006/AMD1:2007 IEC 610004-3:2006/AMD2:2010	Radiated, Radio-Frequency, Electromagnetic Immunity
		IEC 61000-4-4:2012	Electrical Fast Transient/Burst Immunity Test
		IEC 61000-4-5:2014	Immunity to Surges
		IEC 61000-4-6:2013	Conducted, Radio-Frequency, Electromagnetic Immunity Test
		IEC 61000-4-11:2004	Voltage Dips/Interruptions Immunity Test
7.0	Technical Standards used	UL 62368-1:2014 Ed.2	Audio/Video, Information And Communication Technology Equipment - Part 1: Safety Requirements
		CSA C22.2#62368-1:2014 Ed.2	Audio/Video, Information And Communication Technology Equipment - Part 1: Safety Requirements
		CISPR 32 Ed 2.0:2015	Radiated Emissions, AC Mains Conducted Emissions Electromagnetic Compatibility Of Multimedia Equipment - Emission Requirements
		FCC 47CFR PT 15 Sub Part B: April 16, 2019	Radiated Emissions, AC Mains Conducted Emissions Unintentional Radiator
		ISO 7779 Issued:1999/08/01	Acoustics - Measurement of Airborne Noise Emitted by Information Technology and Telecommunications Equipment-Second Edition; Amendment 1: 3/01/2003
8.0	Approval	Place of issue	Moorestown, NJ, USA
		Date of issue	Apr 24, 2019
		Authorized	Scott Maurer,
		Title	President, International Division

Drawing: 92801xx-DoC-UK

Revision: 0.1

0.2. Document History

Doc Rev	Date	Changes (click blue text to go to that page)
19-01	Apr. 30, 2019	Initial release CE compliant
23-01	Jan. 5, 2021	<p>Page 1 - updated OPEX logo</p> <p>Page 2 - updated contact information</p> <p>Page 23 - updated labels per ECO 21-1157</p> <p>Page 24 - location of Feeder Warning label changed</p> <p>Page 25 - location of Pinch Point label changed</p> <p>Page 36 - content added about printer usage</p> <p>Page 39 - edited content and added photos regarding order of operation</p> <p>Page 53 - added detail to printer cartridge replacement</p> <p>Page 70 - corrected physical specifications</p> <p>Page 71 - corrected electrical requirements</p> <p>Page 71 - corrected BTU ratings</p> <p>Page 69 - updated “About OPEX Corporation” text</p>
24-01	Feb. 7, 2024	<p>Reorganized content for uniformity between DMA products. Streamlined text wherever possible. Replaced numerous graphics with photos.</p> <p>Page 1 - updated front cover layout, OPEX logo, and OM410 logo, per marketing standards</p> <p>Page 49 - set up Maintenance as its own chapter</p> <p>Page 61 - set up User Replaceable Parts as its own chapter</p> <p>Page 65 - Transport Cover updated, per ECO21-1004</p>

Table of Contents

0.1. CE Declaration of Conformity	3
0.2. Document History	9

Chapter 1

Introduction

1.1. About This Manual	14
1.1.1. Manual Navigation Aids	14
1.2. Safety message conventions	15
1.3. Safety Guidelines	16
1.3.1. Safety Precautions	16
1.4. Interlock System	17
1.5. Ergonomics	18
1.6. OM410 Labels	18
1.6.1. Feeder Warning Label	19
1.6.2. Pinch Point Caution Label	20
1.6.3. Disconnect Power Warning	21
1.6.4. Dielectric and Ground Test Label	22
1.6.5. FCC Compliance Label	23
1.6.6. Ratings / Serial Number Label	24
1.6.7. ICES-003 Label	25

Chapter 2

Overview

2.1. Main Controls and System Components	28
2.2. Equipment Model/Serial Number Locations	29
2.3. Specifications	30

Chapter 3

Operation

3.1. OM410 Controls	34
---------------------------	----

3.1.1. Keypad Button Functionality	34
3.1.2. The Run Screen	36
3.2. Operating Instructions	39
3.2.1. Order of Operation	39
3.2.2. Output Tray Position	47
3.2.3. Clearing Jams	47

Chapter 4
Maintenance

4.1. Cleaning the OM410	50
4.2. Replacing the Print Cartridge	53
4.2.1. Printer Cartridge Cleaning	55
4.3. Cutter Adjustment	56
4.4. Resetting the Circuit Breaker	58

Chapter 5
User Replaceable Parts

5.1. Overview	62
---------------------	----

Glossary **67**

G.1. List of Terms	68
--------------------------	----

(This page is intentionally blank)

1. Introduction

1.1. About This Manual	14
1.1.1. Manual Navigation Aids	14
1.2. Safety message conventions.	15
1.3. Safety Guidelines	16
1.3.1. Safety Precautions	16
1.4. Interlock System	17
1.5. Ergonomics	18
1.6. OM410 Labels	18
1.6.1. Feeder Warning Label	19
1.6.2. Pinch Point Caution Label	20
1.6.3. Disconnect Power Warning	21
1.6.4. Dielectric and Ground Test Label	22
1.6.5. FCC Compliance Label	23
1.6.6. Ratings / Serial Number Label	24
1.6.7. ICES-003 Label	25

OMATION® Series 410™

Operator Manual

1.1. About This Manual

This manual contains information about the OPEX OMATION® Series 410™ Envelopener® (referred to as “OM410”) and its operational procedures and safety-related components, including:

- safety information, safety hazards and precautions
- main component identification and function
- system specifications

This information is intended for use by the main operator of the OM410. The operator can load envelopes onto the feed hopper, and start the OM410, which will cut open and/or count the envelopes. They can also perform minor maintenance. Read all information thoroughly before attempting to operate or service the OM410.

This manual will be updated to reflect design changes, part number changes, or to correct errors (as detailed in the “Document History” table in the beginning of this manual). Be sure to retain the latest electronic release of the manual for your reference, which can be downloaded in PDF format at www.opexservice.com.

1.1.1. Manual Navigation Aids

The PDF version of this manual is designed for use on a tablet device. To improve navigation, the manual contains blue underlined links you can click on or tap to go directly to a particular page or web address. In addition, all items in the “Table of Contents” as well as the bookmarks in the side bar of the PDF file can be clicked or tapped to navigate directly to a particular page. Make sure to use the latest version of Adobe® Acrobat Reader®* for optimal performance.

*Adobe and Acrobat Reader are registered trademarks of Adobe Systems Incorporated.

1.2. Safety message conventions

This manual uses the following conventions to alert you about safety hazards associated with certain procedures and situations. Please be aware of these conventions when reading the manual and operating the equipment:



DANGER

Indicates a hazardous situation that, if not avoided, will result in death or severe injury. The use of this signal word is limited to the most extreme situations.



WARNING

Indicates a hazardous situation that, if not avoided, could result in death or serious injury.



CAUTION

Indicates a hazardous situation that, if not avoided, could result in minor or moderate injury.

NOTICE

Indicates information considered important, but not hazard related (e.g. messages relating to property damage).

1.3. Safety Guidelines

The information provided in this section is intended to educate you on various safety issues regarding the operation and maintenance of the OM410, and provides an explanation of the safety guidelines to be observed when working with this equipment.

Note: *This manual describes operation of the OM410. If you have a different model, or any optional features, refer to that product's manual before proceeding with this manual.*

1.3.1. Safety Precautions



WARNING

Follow these safety guidelines to avoid injury whenever operating or maintaining the OM410. Failure to follow these precautions may result in severe personal injury or damage to the OM410.

- Be careful when working with AC power. Electrical wiring can be hot any time the OM410 is plugged in.
- Do not move the OM410 while the power is on. Unplug the OM410 from the power source first.
- Do not set liquids/drinks on the OM410 that could spill into it.
- Keep loose objects away from any exposed, moving parts of the OM410. The moving parts of the OM410 can become jammed and/or damaged by foreign objects. Also, keep hands, hair, loose clothing or jewelry away from the moving parts.
- Do not attempt to clean the OM410 while it is running. A cloth (or similar material) should never be used to clean moving parts such as belts or rollers. The use of such material on moving mechanisms can result in damage to the OM410 or severe personal injury.
- Do not use flammable, high pressure, “canned air” to clean paper scraps and dust from the OM410.
- Keep all areas around the OM410 clear of obstacles.

1.4. Interlock System

1. The interlock system will stop all the motors in the OM410 whenever the nip arm cover (Figure 1-1) or chip bin tray (Figure 1-2) is removed.



Figure 1-1: Top cover removal interlock triggering



Figure 1-2: Bin tray removal interlock triggering

1.5. Ergonomics

As in any occupation that requires you to perform the same motion repeatedly during the course of your work, it is important to consider how you perform your task. Listed below are some guidelines to help you minimize the risk of physical discomfort and injury while operating the OM410.

- Maintain an upright body posture.
- Occasionally change the angle of your posture for greater comfort.
- Avoid operating the OM410 for longer than a single 10-hour shift. If possible, stretch between breaks.

1.6. OM410 Labels

Labels are used in specific locations on the OM410 to alert you to certain safety hazards and provide important information about the OM410. In many cases, there are different versions of the same label: some are bilingual, while others have no text for international OM410s. Though they appear different, the locations of these labels are identical.



Follow the safety precautions on all labels when operating the OM410. Failure to follow these precautions may result in severe bodily injury or death as well as damage to the OM410.

1.6.1. Feeder Warning Label

Location: Front of the OM410 on the feeder (Figure 1-3).

Purpose: To warn personnel that hair, loose clothing, or jewelry should be kept away from this area.

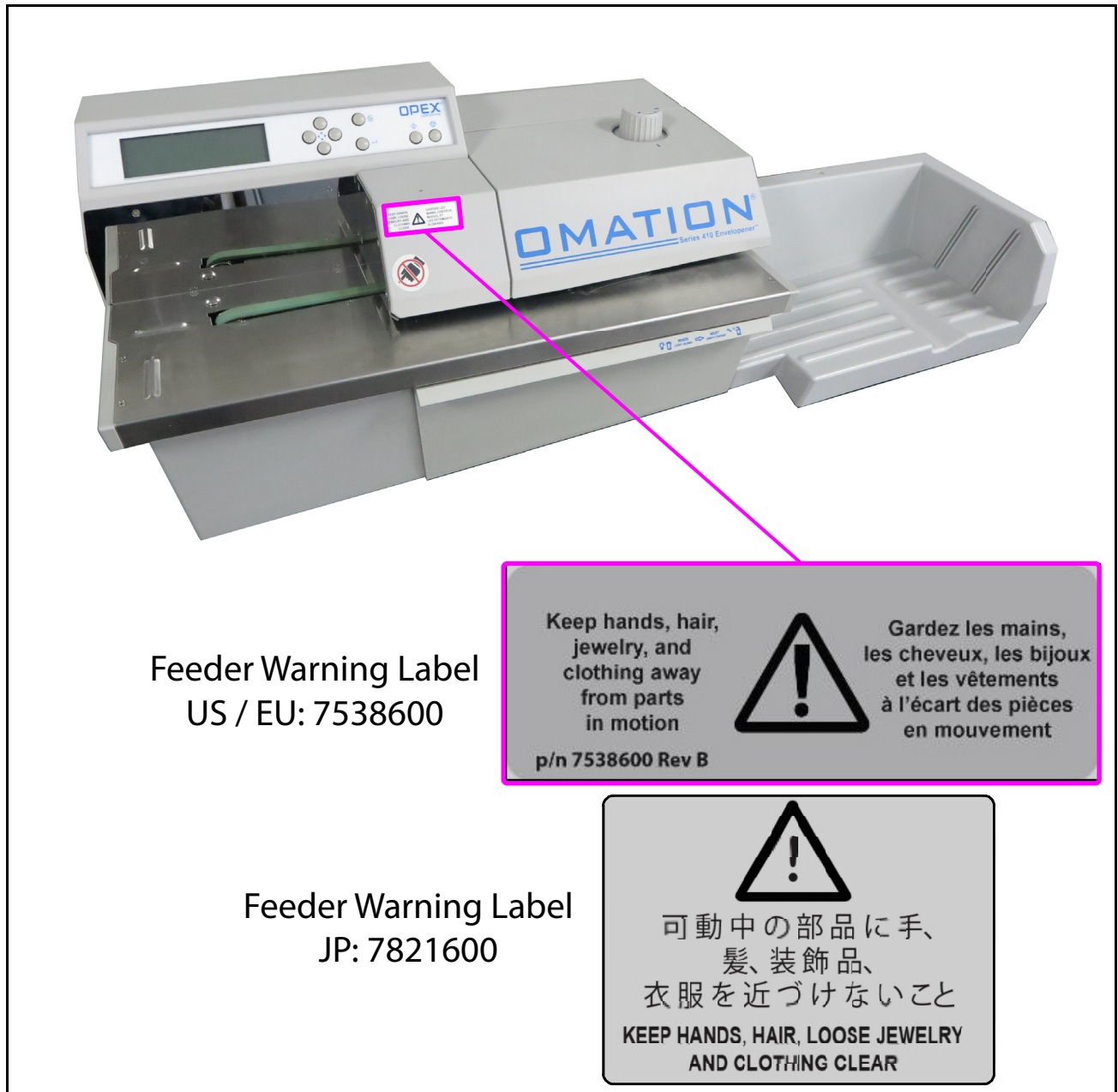

Figure 1-3: Feeder Warning label

1.6.2. Pinch Point Caution Label

Location: The beginning and end of the feed belt path (Figure 1-4).

Purpose: Warns about pinch hazards near the feed belt.



Figure 1-4: Pinch Point label 1637200

1.6.3. Disconnect Power Warning

Location: Rear of the OM410 (Figure 1-5).

Purpose: Warns personnel to disconnect power before opening the OM410.



Figure 1-5: Disconnect Power Before Opening label

1.6.4. Dielectric and Ground Test Label

Location: Rear of the OM410 (Figure 1-6).

Purpose: To inform personnel that the ground points in the OM410 are well connected between each other and it has passed the ground bond test.



Figure 1-6: Dielectric and Ground Test Label P24838-01

1.6.5. FCC Compliance Label

Location: Rear of US OM410s only (Figure 1-7).

Purpose: Certifies that the electromagnetic interference from the device is under the limits approved by the Federal Communications Commission.

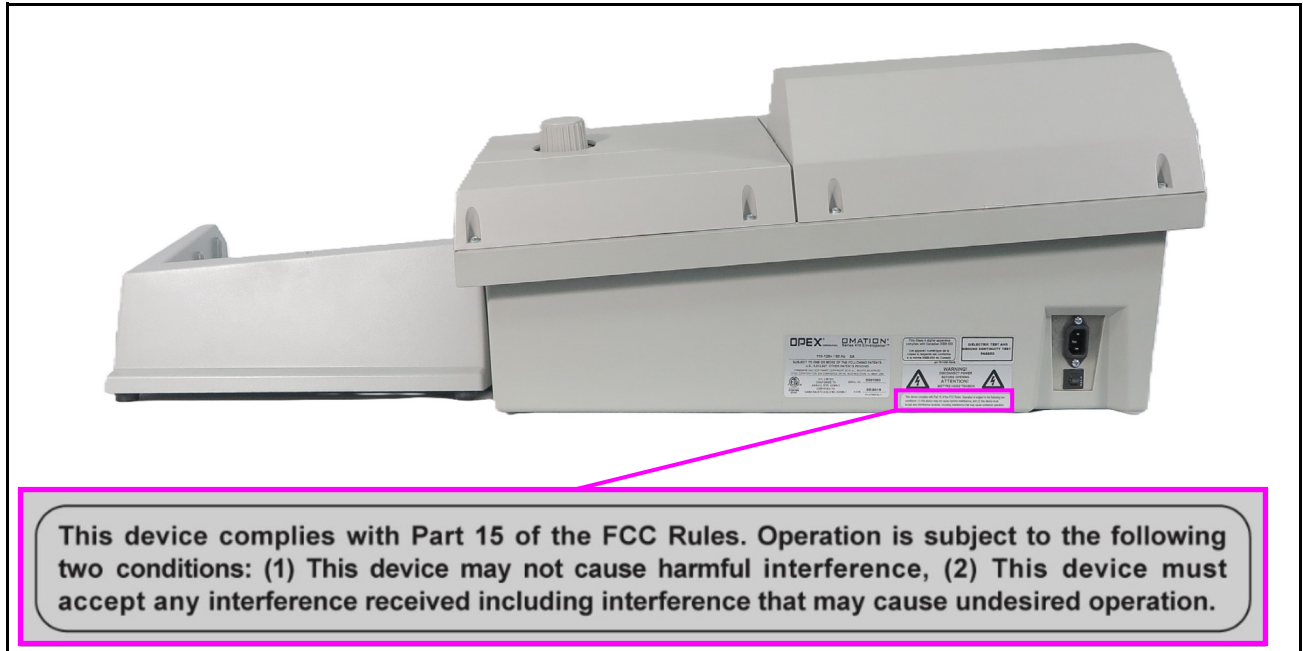

Figure 1-7: FCC Compliance Label P24839-03

1.6.6. Ratings / Serial Number Label

Location: Rear of OM410 (Figure 1-8).

Purpose: Identifies product model, electrical ratings, serial number for U.S. & Canada; EU; Japan.

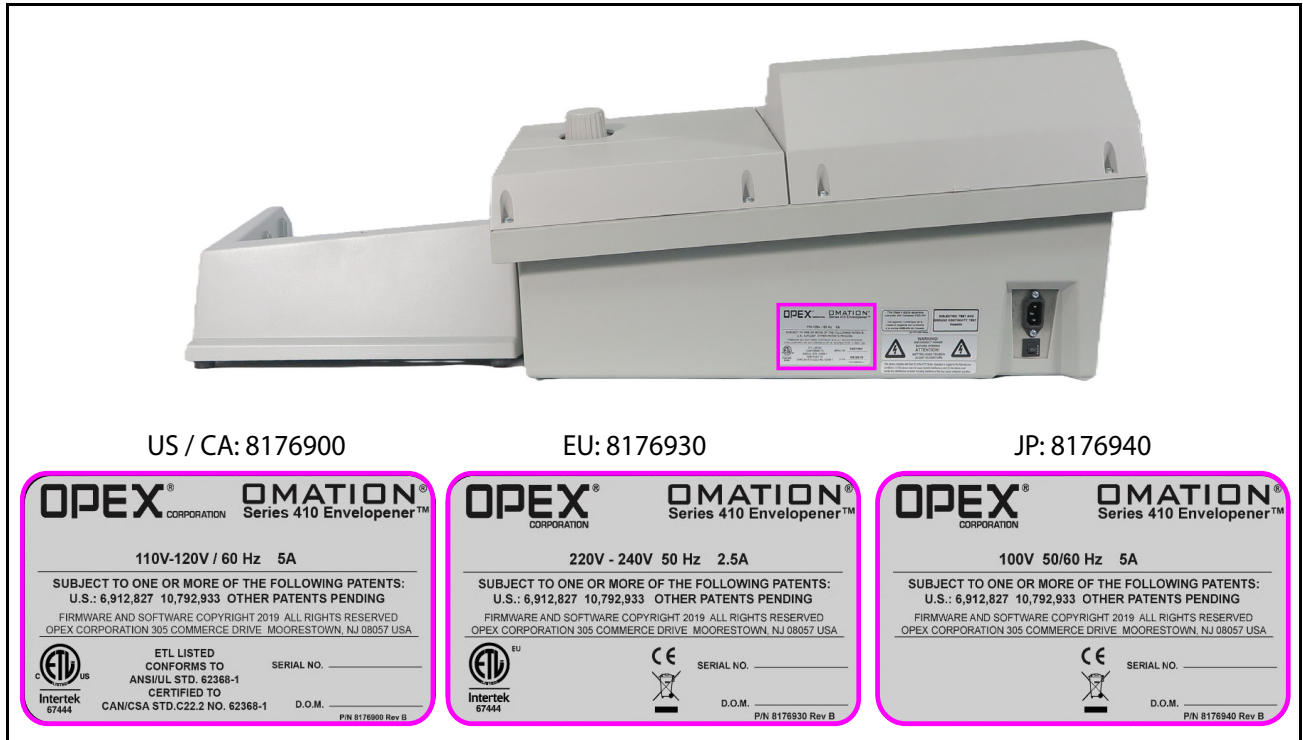

Figure 1-8: Model / Serial Label

1.6.7. ICES-003 Label

Location: Rear of North American OM410s only (Figure 1-9).

Purpose: This label (7611000) identifies compliance with Canadian ICES-003.



Figure 1-9: ICES-003 Label

(This page is intentionally blank)

2. Overview

2.1. Main Controls and System Components	28
2.2. Equipment Model/Serial Number Locations.....	29
2.3. Specifications	30

2.1. Main Controls and System Components

The OM410 is a high-speed envelope opener that can open, count, and print on envelopes. Features include:

- Advanced self-adjusting feeder for efficient mixed mail opening
- Milling cutter that can remove as little as 0.010" of a chip
- Printer which can print date, time, and/or a sequence number
- Enhanced chip management/chip capacity
- Three depths of cut and a no-cut option
- Large variety of mail types

Please take time to familiarize yourself with the various parts of the OM410, shown in Figure 2-1.

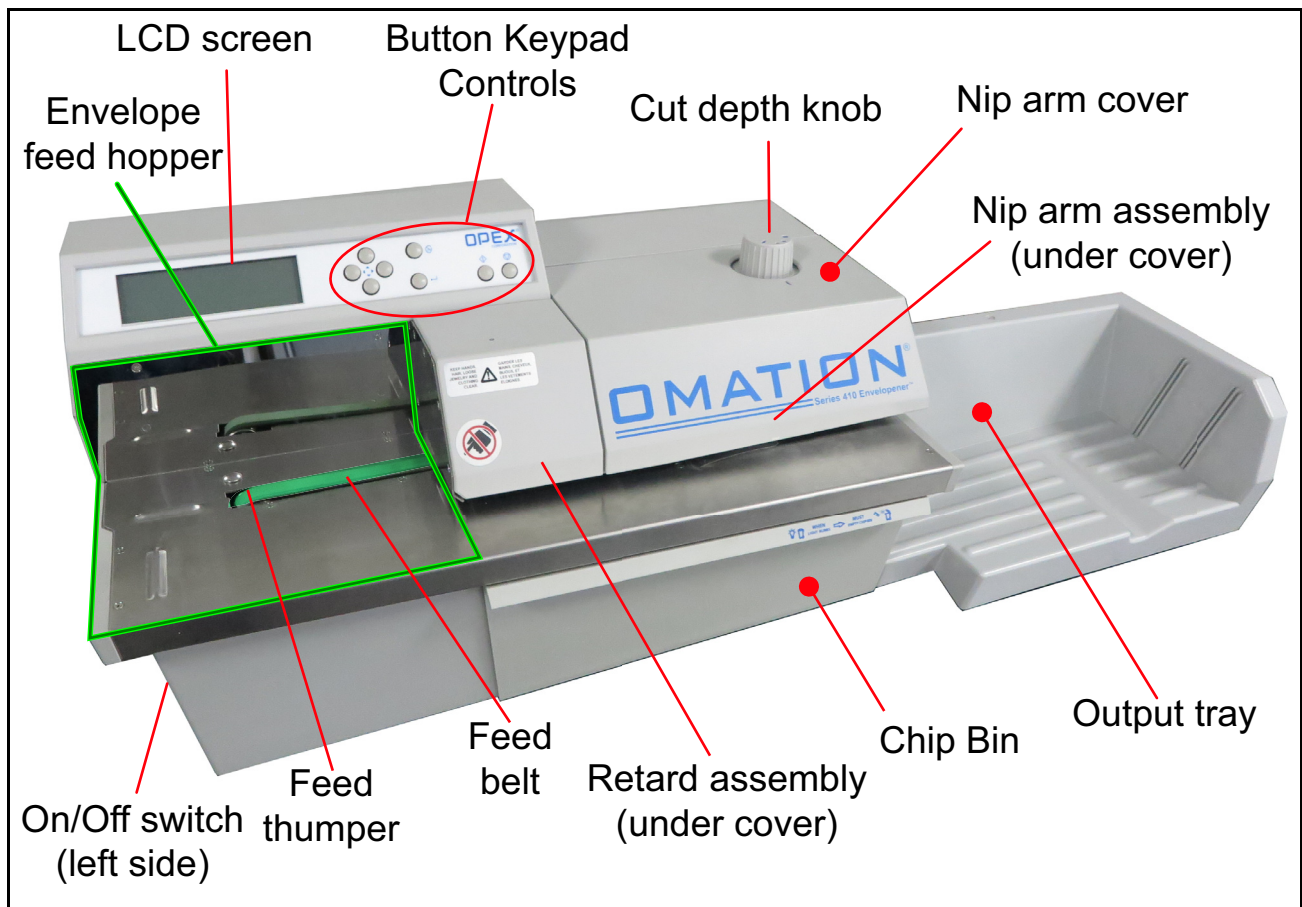

Figure 2-1: Main Components Front View

2.2. Equipment Model/Serial Number Locations

Before contacting OPEX Technical Support, locate the Model/Serial label on your OM410 so that you can provide the assisting technician with your Reference Serial Number (Figure 2-2). See [“Contacting OPEX” on page 2](#) for contact information.

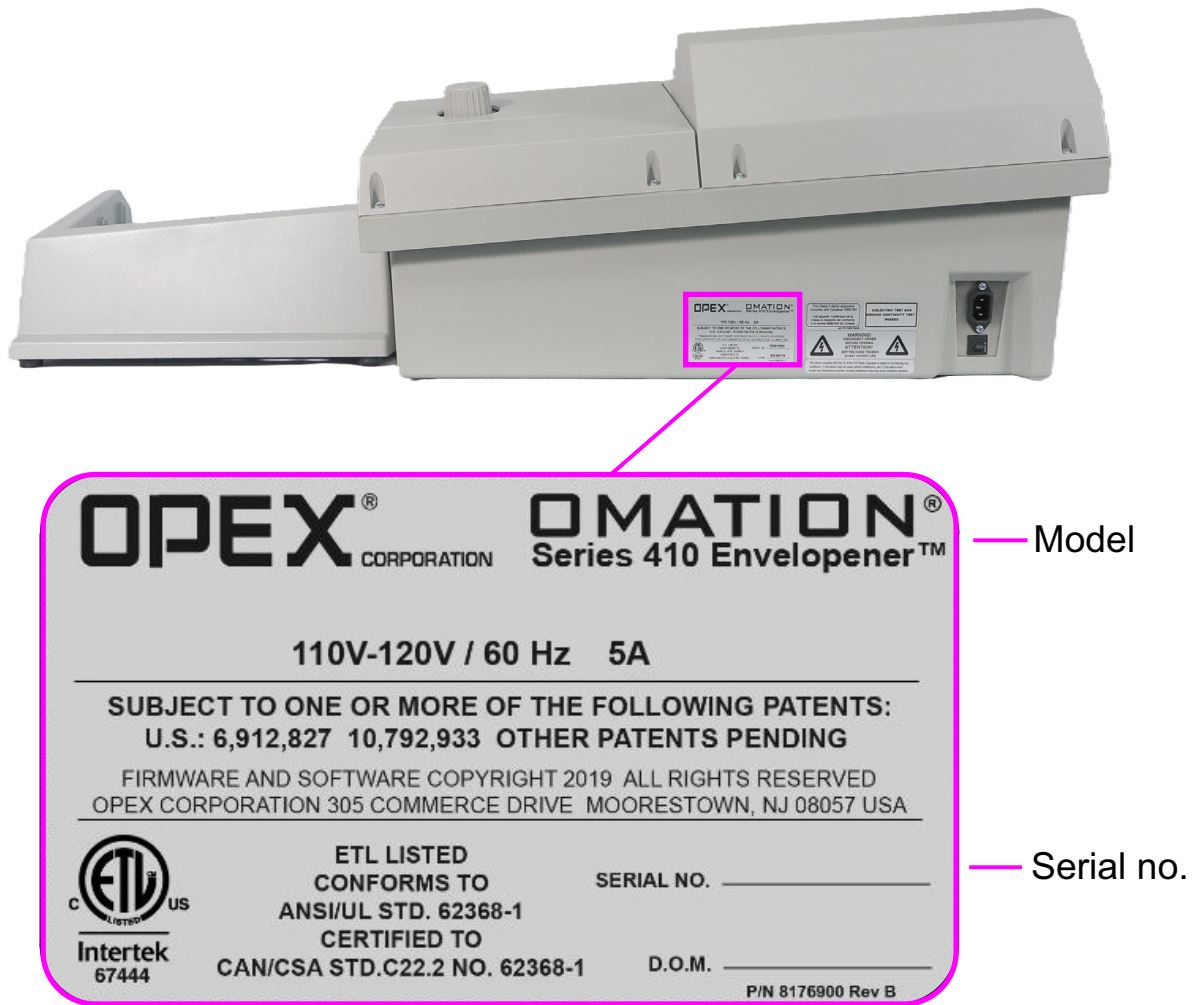

Figure 2-2: Model/Serial label

2.3. Specifications

Table 2-1: OM410 Specifications

Specification	Value
Processing Speed	Up to 400 envelopes / minute (using 6" envelopes)
Envelope Specifications	Min. length: 3.50" Max. length: 14.00" Min. height: 3.00" Max. height: 9.50" Thickness: Up to 0.188" (4.8 mm)
Default Cutter Settings	<ul style="list-style-type: none"> • No-cut setting • Cut depth 1 = 0.010" (0.254mm) • Cut depth 2 = 0.014" (0.356mm) • Cut depth 3 = 0.060" (1.524mm) <p>Note: The cut adjustment screw changes the cut depth 0.0044" for every ¼ turn of the screw. Cut depths range from 0.01"- 0.07" (0.25mm - 1.79mm).</p>
Printer	Can print: Date, Time, and/or Sequence number
Daily Duty Cycle	2000 (tested with #7 envelopes, printing date, time, and sequence number with a 2-hour cooling down rest period before printing again)
Physical Dimensions	Height: 14.3" (363.22 mm) Length: 40.3" to 42.3" (1023.62 mm to 1074.42 mm) Depth: 16.5" (419.1 mm) <ul style="list-style-type: none"> • with power cord connected: 18" (457.2 mm) Weight: 55 lbs (24.95 kg) with cord and catch tray

Table 2-2: Electrical Requirements

Specification	Value
Power	<ul style="list-style-type: none">• US / CA: 100-120 VAC, 60HZ, 5A• EU / AU: 220-240 VAC, 50HZ, 2.5A• JP: 100 VAC, 50/60HZ, 5A

Table 2-3: Environmental Specifications

Specification	Value
BTU Rating	<ul style="list-style-type: none">• US / CA/ EU / AU: 2050 BTU/hour• JP: 1708 BTU/hour
Operating and Storage Temperature range	40°F – 100°F(4.4°C – 37.8°C), Humidity 10 – 90% Non-condensed.
Decibel Rating	Does not exceed safety standard of 80 dB.

(This page is intentionally blank)

3. Operation

3.1. OM410 Controls	34
3.1.1. Keypad Button Functionality	34
3.1.2. The Run Screen	36
3.2. Operating Instructions	39
3.2.1. Order of Operation	39
3.2.2. Output Tray Position	47
3.2.3. Clearing Jams	47

3.1. OM410 Controls

3.1.1. Keypad Button Functionality

The OM410 controls are located on the keypad to the right of the LCD screen as indicated in Figure 3-1.

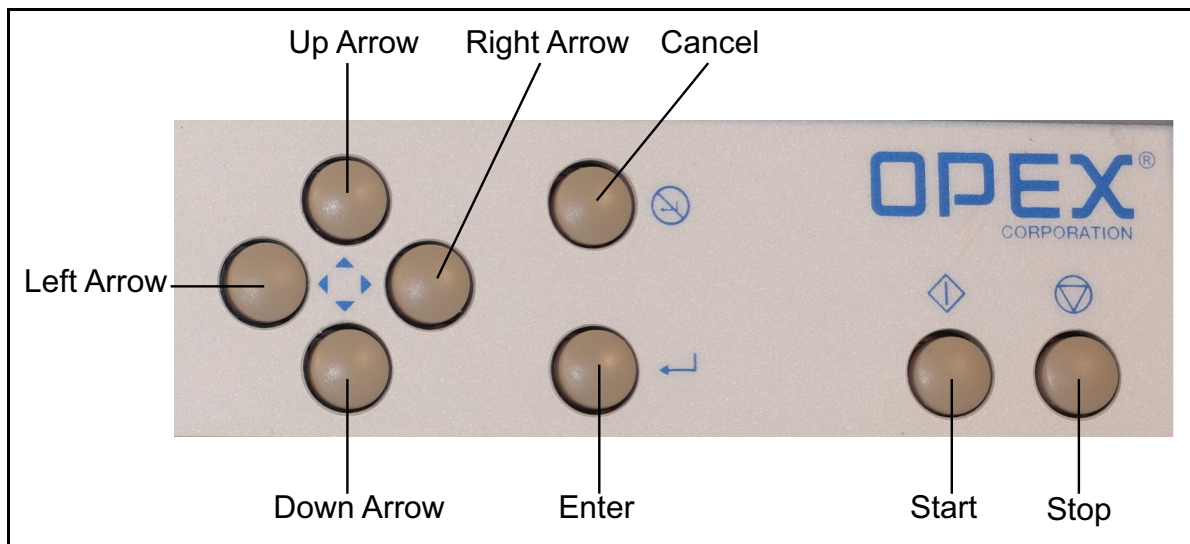

Figure 3-1: OM410 keypad button names

Start button - turns on the OM410.

Stop button - turns off the OM410 display.

Enter button - used to make selections that are shown on the LCD display.

Cancel button - used to cancel actions (such as to stop a job run), or back out of a screen.

Arrow buttons - navigate through the data on the LCD screen.

3.1.1.1. Arrow button functionality

Up Arrow Press - will allow you to navigate up through a column of data. When the upper item within the column is highlighted and you press the up key, the list of data is shifted down by a row and the previous line of data is displayed. If the up arrow is pressed while on the first row of data, then the cursor will move left to the first item in the table. If the first item is selected, then the cursor will move to the last item in the list.

Up Arrow Hold - Pressing and holding the up arrow will display the previous full page of data. The screen will wrap to the last page of data when you hold the up arrow while the first page of data is displayed. When the screen wraps to the last page, the last item in the list will be highlighted.

Down Arrow Press - will allow you to navigate down through a column of data. When the lower item within the column is highlighted and you press the down arrow, the list of data is shifted up by a row and the next line of data is displayed. If the down arrow is pressed while on the last row, the cursor will move left to the last item in the table. The screen will wrap to the first item in the list if you press the down arrow when the last item in the list is highlighted.

Down Arrow Hold - Pressing and holding the down arrow will display the next full page of data. The screen will wrap to the first full page of data when you hold the down arrow while the last page of data is displayed. The first item in the list will be selected when the screen wraps to the first page.

Left Arrow Press - will shift the highlighted selection one column to the left. If the selected item is in the first row and the left arrow is pressed, then the last item in the previous row will be selected. In addition, if the first item on the page is highlighted and the left arrow is pressed, the list is shifted down and the previous line of data is displayed. Pressing the left arrow while the first item on first page is highlighted will cause the screen to wrap to the last item in the list.

Left Arrow Hold - Left arrow hold will continuously shift the selection one item to the left until the key is released. It will work the same as the left arrow press.

Right Arrow Press - will shift the highlighted selection one column to the right. If the selected item is in the last row and the right arrow is pressed, then the first item in the next row will be selected. In addition, if the last item on the page is highlighted and the left arrow is pressed, the list is shifted up and the next line of data is displayed. Pressing the right arrow while the last item on the last page is highlighted will cause the screen to wrap to the first item in the list.

Right Arrow Hold - will continuously shift the selection one item to the right until the key is released. It will work the same as the right arrow press.

3.1.2. The Run Screen

All of the basic Operator functions can be accessed right from the Run screen.

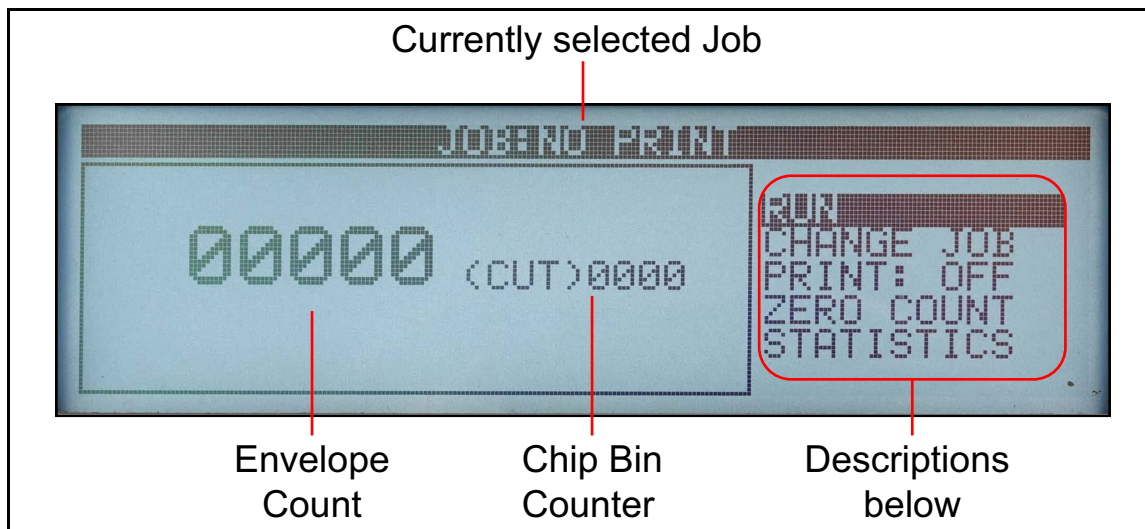

Figure 3-2: Run screen

- The run screen will show overall Envelope counts with the large counter
- The smaller **(CUT)** counter is how many envelopes have been cut, and is reset every time the chip bin is removed

3.1.2.1. RUN

This selection will turn the motor on to process mail using the currently selected job.

3.1.2.2. CHANGE JOB

This selection will allow the operator to change the currently selected job.

3.1.2.3. PRINT

In jobs that have printing enabled, this will be set to **ON**. This will allow the operator to temporarily turn audit trail printing off and on. This capability was provided in case there is an issue with the printer and the operator wants to run mail without correcting that issue. Printing cannot be turned on if running the No Print job.

For jobs with printing enabled, the following practices are recommended to ensure maximum printer cartridge lifespan:

- Limit daily usage to no more than 2000 envelopes. If processing larger numbers of envelopes, break the job into multiple jobs to allow the printer to cool. The OM410 can still be used to open envelopes while the printer cartridge cools. Processing mail continually without printer cool-down periods can result in reduced printer cartridge life.
- Switch off the OM410 when not in use.

Note: When turning printing back on, the OM410 will ask if you want it to “spit”. See *Spit Option* below.

3.1.2.3.1. Spit Option

The **SPIT** option appears before **ON** when cycling through the print options. This sprays ink from the print nozzles as a way to clean the heads of the cartridge. It is recommended to perform this procedure every two weeks, so that the printer jets are cleaned out (see [page 53](#) for additional cleaning recommendations).

The print nozzles can be cleaned by placing a piece of paper under the print head, selecting **SPIT**, and pressing the **down arrow**.

3.1.2.4. ZERO COUNT

This will allow the user to reset the statistics counters for the current run. At the beginning of a run or at any point during a run, a user may reset the counters. This will cause the software to zero all of the counts on the screen, close out the current statistics “record,” and open up a new one.

3.1.2.5. STATISTICS

This will show the **DISPLAY STATISTICS** screen, which will allow the user to display and optionally print their statistics (Figure 3-3).

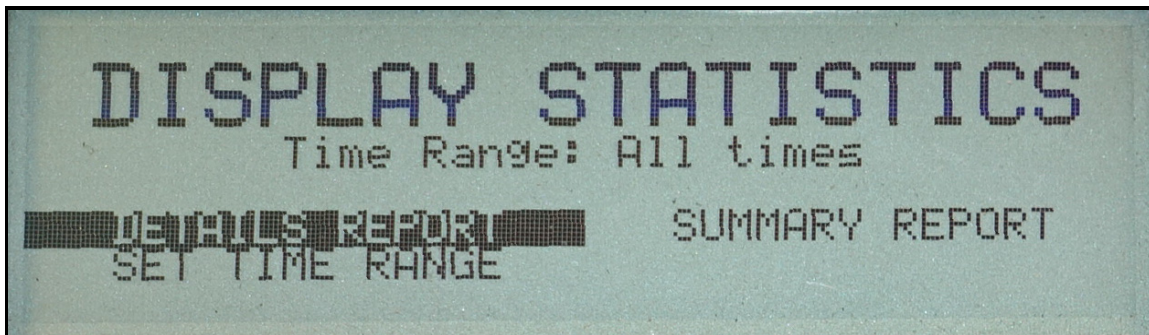

Figure 3-3: Display Statistics screen

- **DETAILS REPORT** - Pulls together all jobs run in the specified time range in their each individual view (example: if the operator ran four jobs, the data will be pulled together into four views).
- **SUMMARY** - Pulls together all jobs run within the specified time range in one view.
- **SET TIME RANGE** - allows operator to set specified date and time for pulling the above information together.

3.1.2.6. Printing on the Envelopes

Through the Select Job menu (Figure 3-4), the OM410 can be set to not print; or print the date, the time a piece was processed, its sequence number, or any combination of the three.

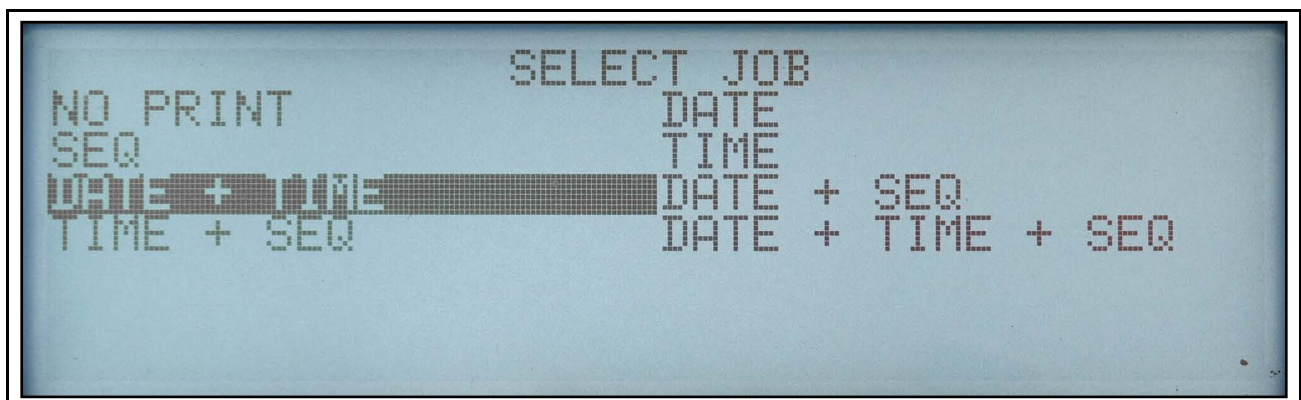

Figure 3-4: Printing via Jobs

3.2. Operating Instructions

3.2.1. Order of Operation

1. Connect the power cord to the OM410 (Figure 3-5) and the other end into an AC-supplied outlet.



Figure 3-5: AC input on back

2. Connect the output tray on the right side of the OM410 (as shown on [page 47](#)).

3. Press the “1” position on the AC power switch on the left side of the OM410 to supply power to the OM410 (Figure 3-6).



Figure 3-6: AC power switch

4. Press the **Start button** to turn the OM410 on (Figure 3-7). This will bring up the **RUN** screen.

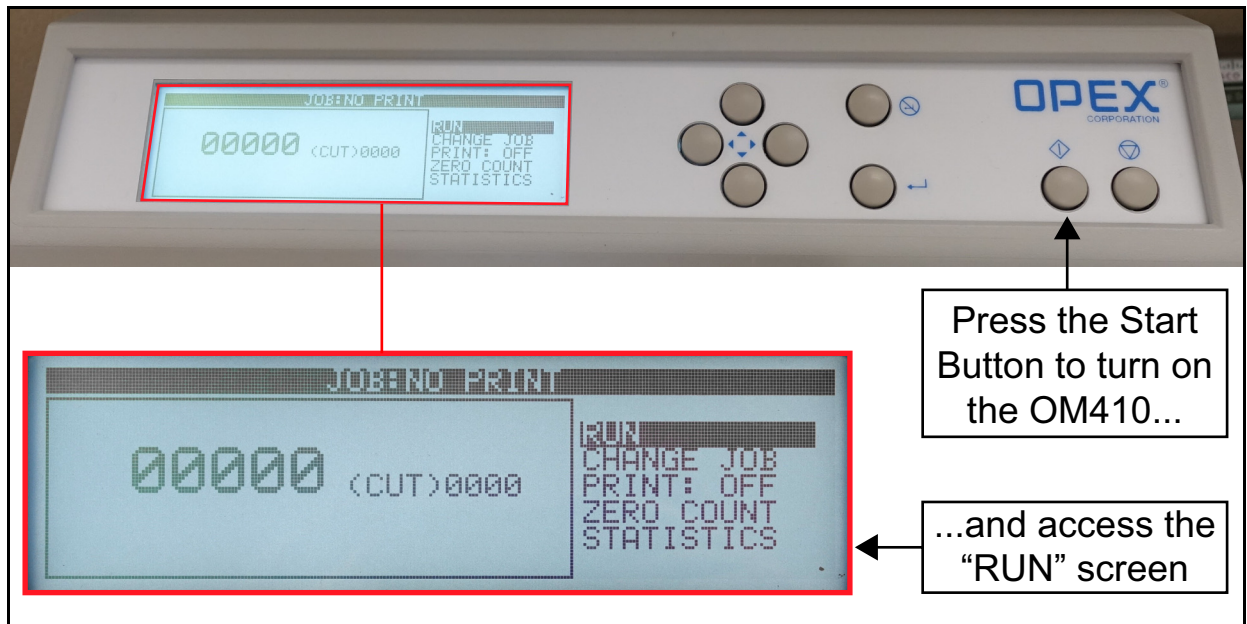

Figure 3-7: Start Button

5. Use the arrow buttons to highlight **ZERO COUNT**, then press the **Enter** button to reset the count (Figure 3-8).

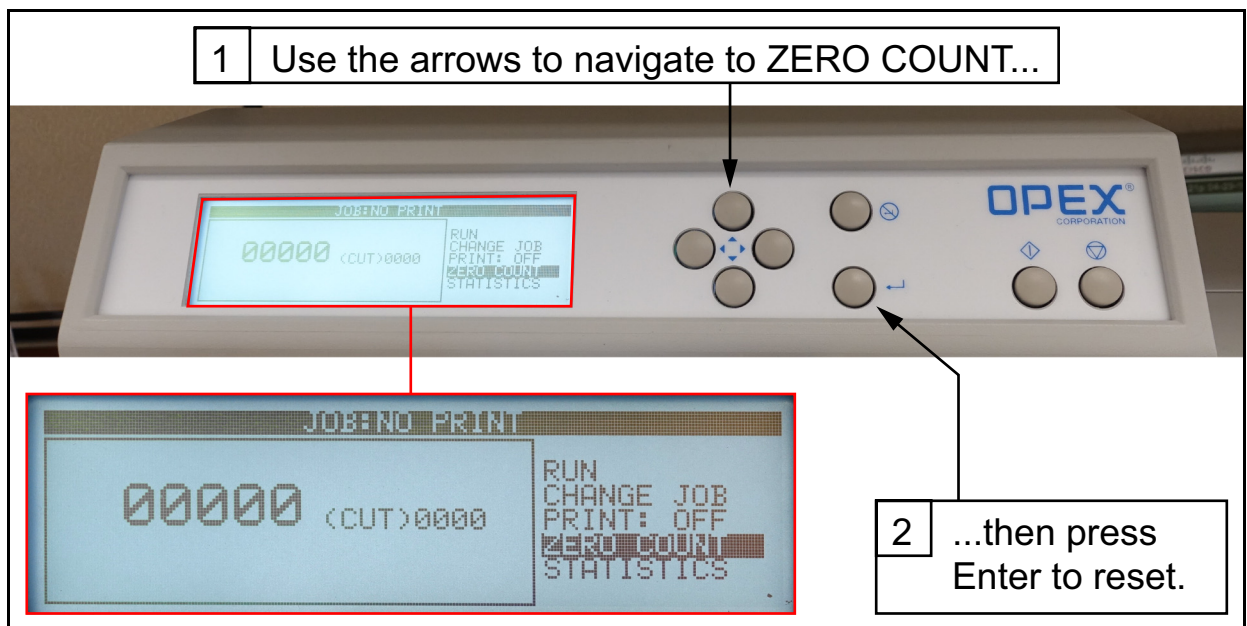

Figure 3-8: Resetting the counter

6. Access the **Select Job** screen by using the **arrows** to highlight **CHANGE JOB** in the menu, and then press the **Enter** button (Figure 3-9).

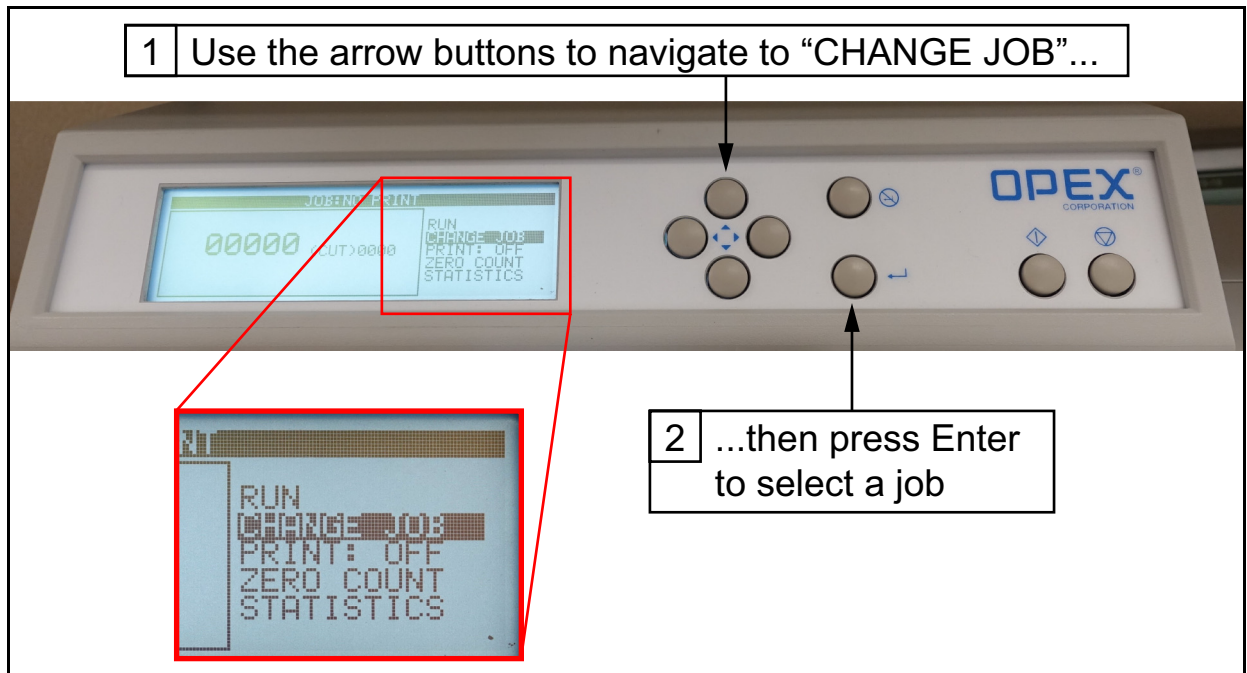

Figure 3-9: Getting to the Select Job screen

7. Select a job by highlighting it with the **arrow** buttons, and then pressing **Enter** (Figure 3-9).

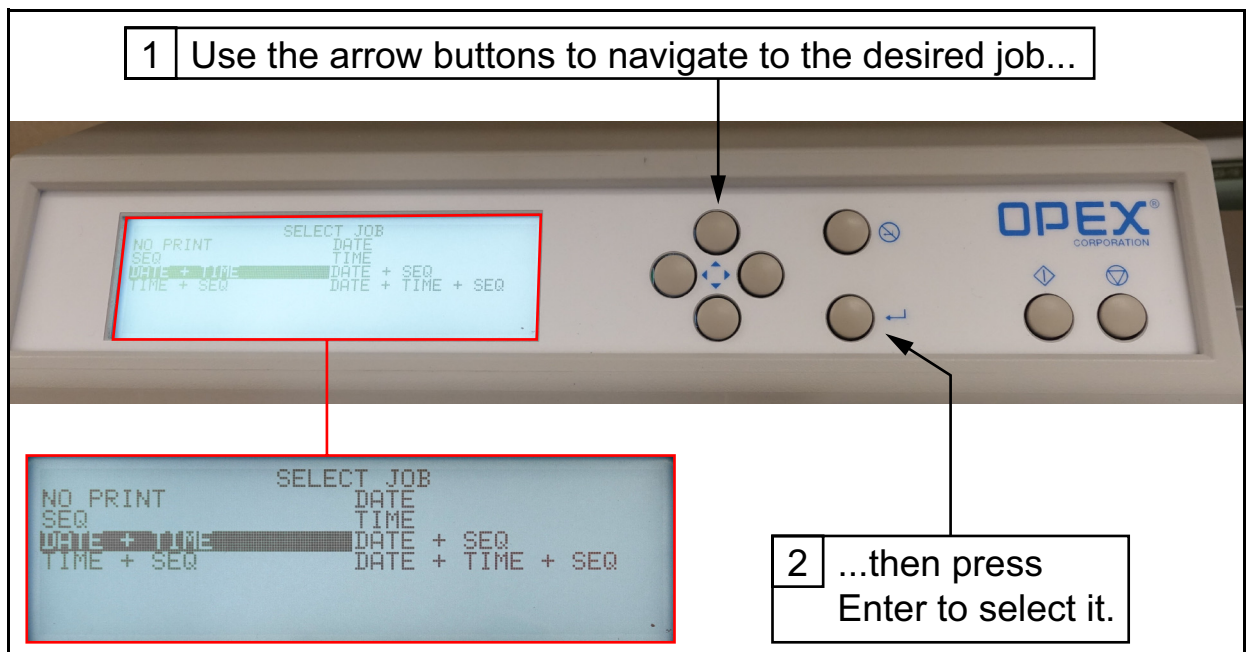

Figure 3-10: Selecting the Date + Time job

8. The display will return to the **Run** screen, with the job name displayed at the top. At this time, you should set the cutter depth knob (Figure 3-11) for the desired cut. Position 1 is the shallowest cut, and 3 is the deepest.

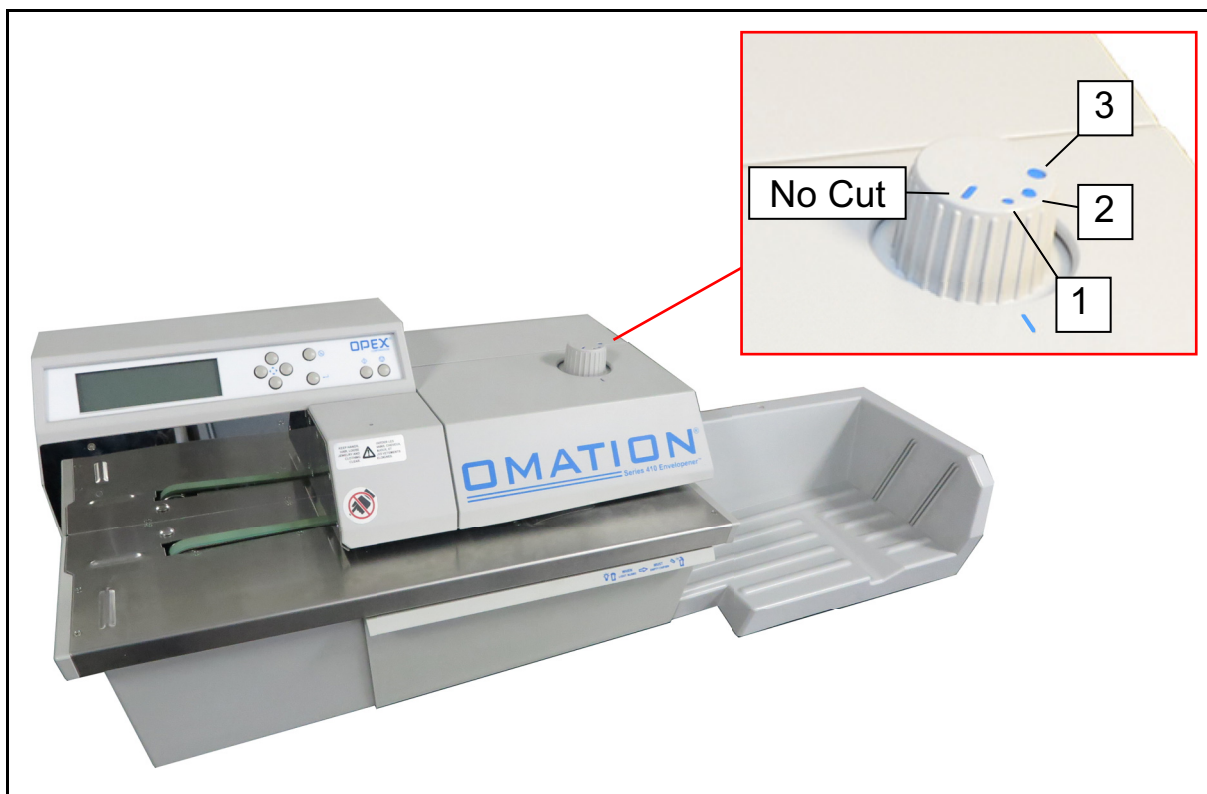

Figure 3-11: Setting the cut depth

9. Once ready to begin, use the arrow buttons to highlight **Run**, and then press **Enter** to start the OM410 (Figure 3-12). The screen will display “RUN MODE ACTIVE” and elapsed run time.

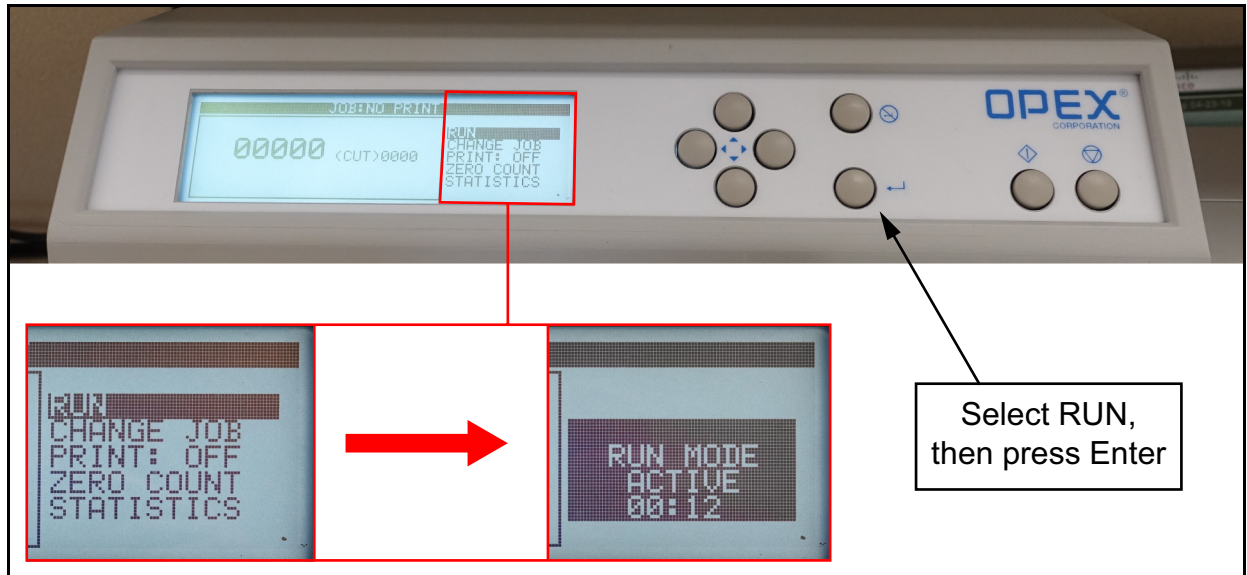

Figure 3-12: Starting the OM410

The mail stack can be placed on the feed hopper while it is stopped, but it will perform better if the OM410 is on when the mail is put on the feed belt. It is also better to put the mail on the belt without dropping or throwing it.

10. Put a handful of mail (approximately 25-50 pieces) flush against the back of the feed hopper and the side wall, and then release the stack when the

front edge of the mail is $\frac{1}{2}$ to $\frac{3}{4}$ of an inch above the transport deck (Figure 3-13).



Figure 3-13: Mail flush against Feed Hopper wall

- The Feed Thumper (a rotating cam Figure 3-14) helps to jog the mail for improved feeding.

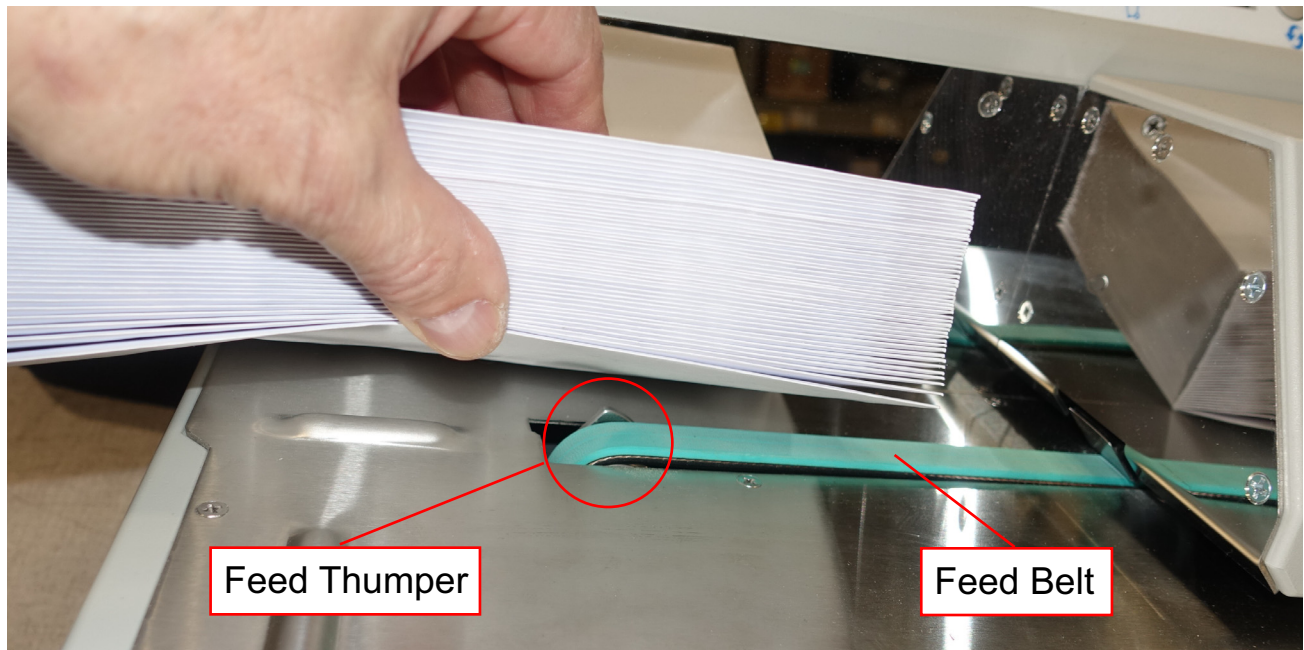

Figure 3-14: Feed Thumper

11. The feed belt pulls the mail into the retard assembly where it is singulated (separated one at a time).
12. The nip arm assembly guides the individual envelope under the printer where the envelope can be printed on, if a print job option is selected.
13. The envelope then passes under the cutter which will open it if the cutter depth knob is set for one of the cut options.
14. The envelope is then passed through the counter sensor and counted (the mail is always counted even if it is not cut).
15. The envelope then moves into the mail output tray.
16. Once the Envelope Feed Hopper is empty, empty the output tray.
17. To continue processing, load more mail onto the Envelope Feed Hopper.

3.2.2. Output Tray Position

The position of the output tray can be adjusted for processing larger envelopes. Simply lift the output tray up, move it to the desired position, and press it down onto the stepped tray hitch (see Figure 3-15).

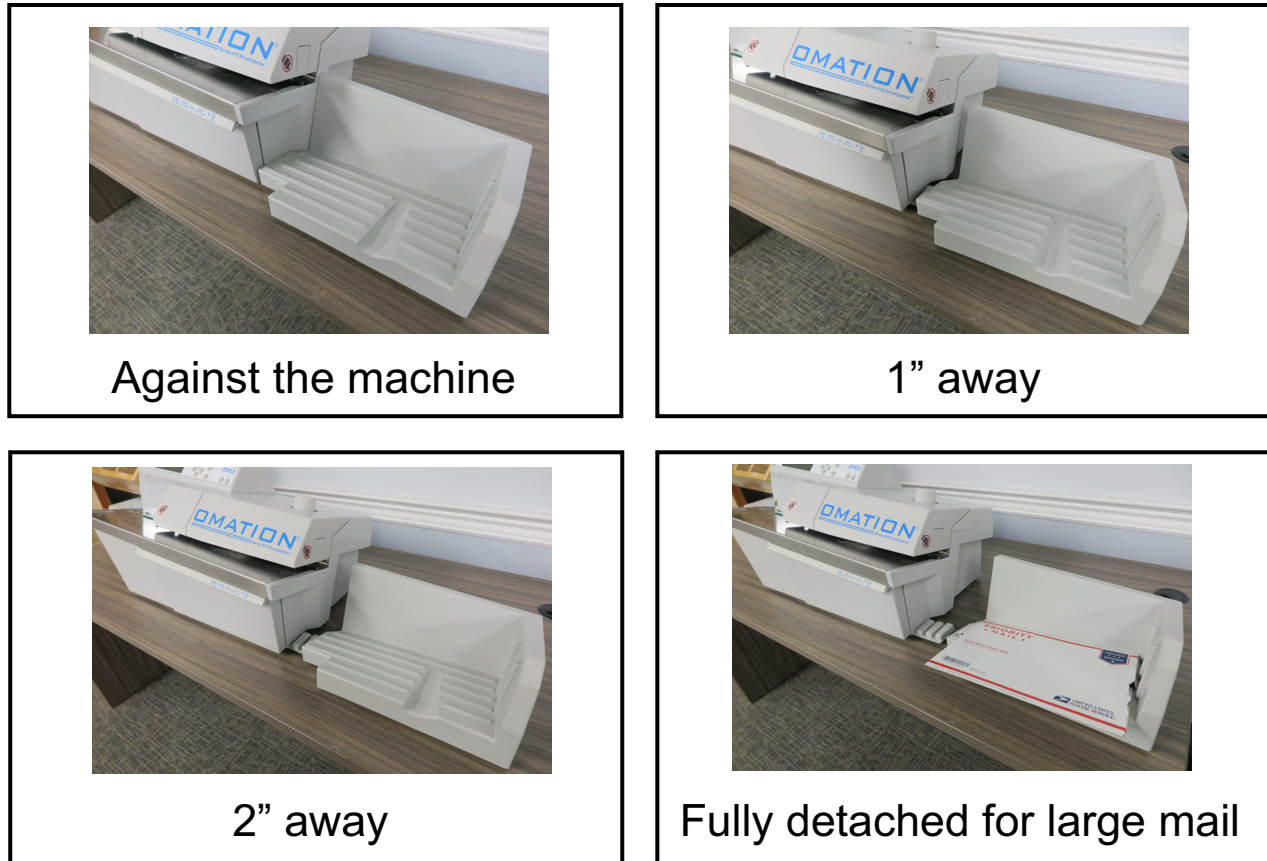

Figure 3-15: Output tray positions

Note: [Click here](#) to return/go to the “Order of Operation” steps.

3.2.3. Clearing Jams

From time-to-time, you will experience the inevitable jam. A “jam” refers to any occurrence that causes the OM410 to stop, not necessarily because an item is physically jammed in the OM410. You may have to remove the nip arm cover. This is described in [“Cleaning the OM410” on page 50](#).

(This page is intentionally blank)

4

4. Maintenance

4.1. Cleaning the OM410	50
4.2. Replacing the Print Cartridge	53
4.2.1. Printer Cartridge Cleaning	55
4.3. Cutter Adjustment	56
4.4. Resetting the Circuit Breaker	58

4.1. Cleaning the OM410

To keep the OM410 in good working order and prolong lifespan, it is recommended that the following cleaning procedure be performed daily:

1. Turn off the AC power switch on the left side of the OM410.
2. Unplug the AC power cord from the back of the OM410.
3. Press the catch release button on the right side of the cover until a “click” is heard, and lift the right side (Figure 4-1).

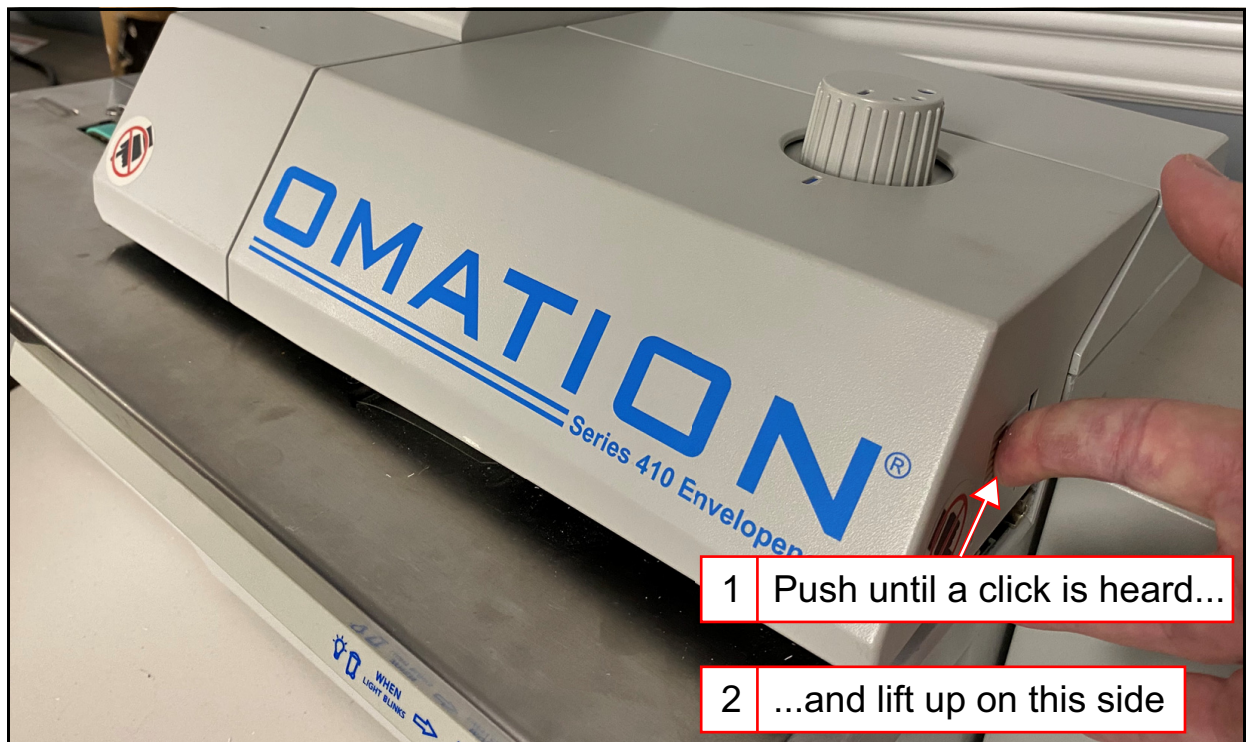

Figure 4-1: Cover catch release button

4. Continue lifting the cover off on the left side to remove it (Figure 4-2).



Figure 4-2: Lifting the Nip arm cover

5. Lift the Nip arm wheels to clean under them (Figure 4-3).



Figure 4-3: Lifting the nip wheels

6. Remove and empty the chip bin.
7. Vacuum loose paper chips and debris from the OM410.
8. Use a cloth moistened with liquid cleaner to wipe down the exterior of the OM410.
 - Use denatured alcohol on areas with stains, if necessary.
 - Any non-flammable commercially available cleaning solution may be used to clean the OM410. When cleaning the OM410, DO NOT USE aerosol cleaners or compressed air, because of the flammable nature of many of these products. There is a risk of equipment malfunction and/or injury associated with the use of aerosol cleaners on OPEX equipment prior to the operation of equipment.
 - When cleaning glass and plastic surfaces, use detergent-based cleaners such as Fantastik® or Formula 409®. Detergent-based cleaners are recommended, because they do not cause component degradation.



CAUTION

A cloth soaked with cleaning detergent or similar material should never be used to clean an object such as a belt or roller when the belt or roller is being driven by the system. Use of a cloth or similar material on moving mechanisms can result in personal injury. If a belt, pulley or similar part needs to be cleaned, it should be cleaned while stationary or unplugged.

- Wipe dust and debris from the sensors. Debris build-up can cause jams. Accumulations of dirt and debris can cover sensors, preventing them from working effectively. This will hinder OM410 performance.
9. Re-install the chip bin and nip arm cover.

4.2. Replacing the Print Cartridge

The daily duty cycle is 2000 envelopes. Continuously running the OM410 will shorten the life of the printer cartridge due to overheating the printer heads.

If the print becomes faded, parts of the numbers disappear, or it looks like a line of no ink passes through the text, then the ink cartridge should be cleaned with the printer spit function (see [page 37](#)). If this does not clean up the print, then the cartridge should be removed and cleaned with an alcohol wipe. If after several attempts, this does not improve print quality, then the cartridge should be replaced.

Note: *Not cleaning the cartridge to correct print quality issues may result in more frequent cartridge replacement.*

To replace the printer cartridge:

1. Turn off the AC power switch on the left side of the OM410.
2. Unplug the AC power cord from the back of the OM410.
3. Remove the Nip Arm Cover (as shown on [page 50](#)) to expose the printer cartridge (Figure 4-4).

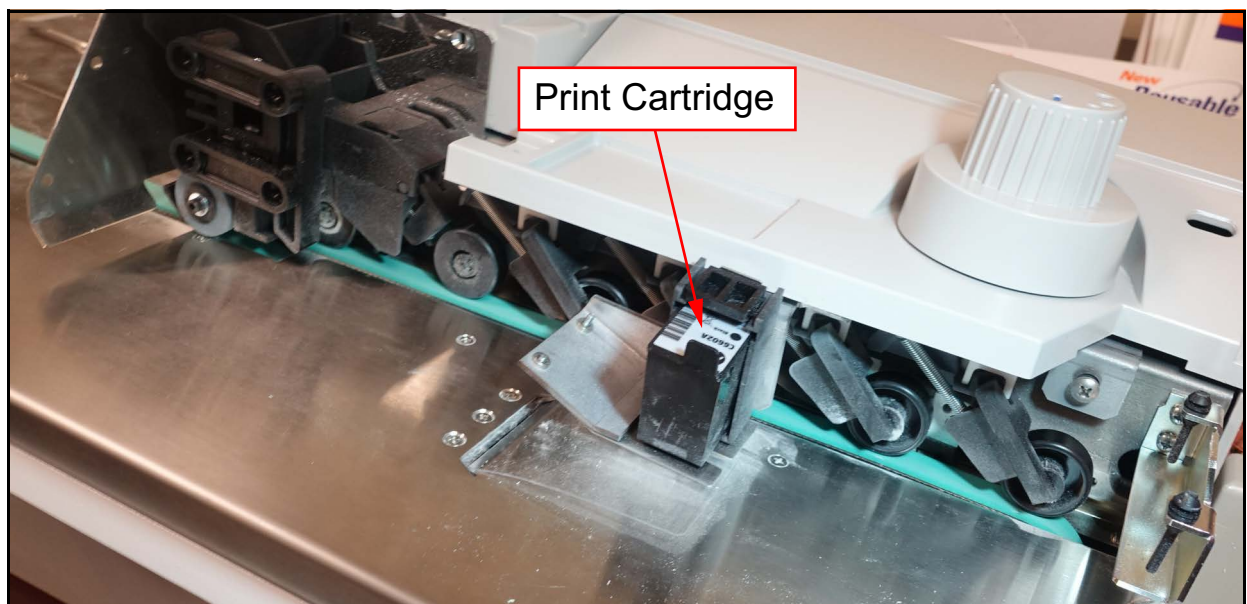

Figure 4-4: Printer Cartridge

4. Grasp the tab on the printer cartridge and pull in an arc motion (Figure 4-5).

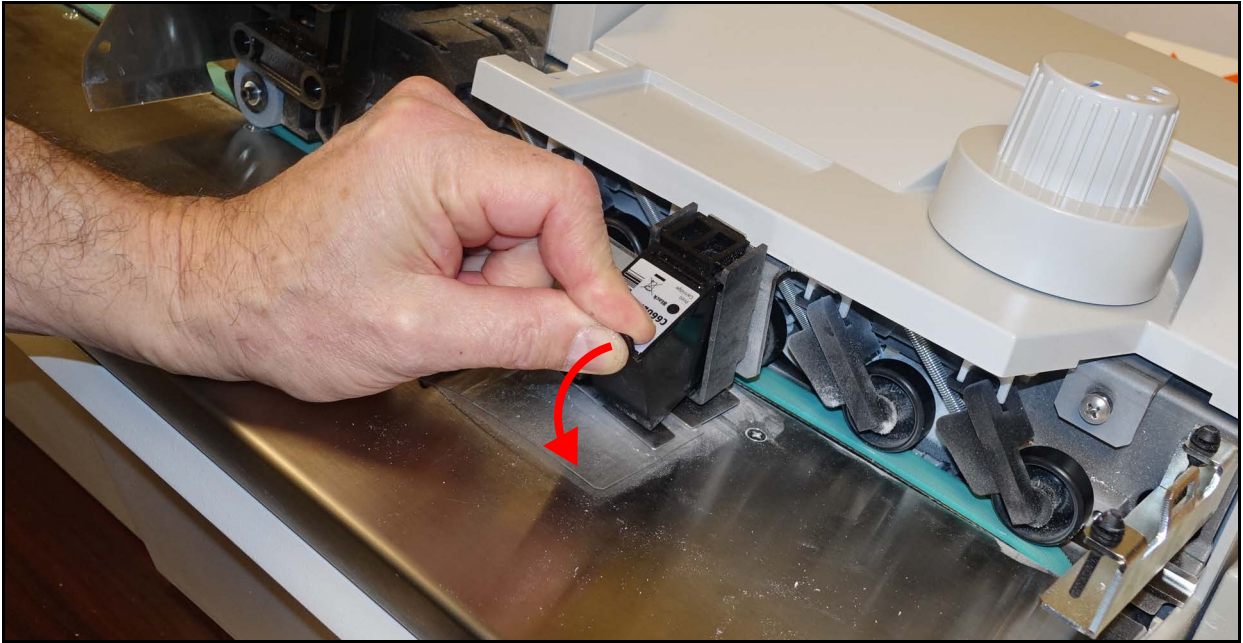

Figure 4-5: Removing the print cartridge

5. Replace the printer cartridge and push into place (Figure 4-6).



Figure 4-6: Replacing the printer cartridge

6. Replace the Nip Arm Cover and run a printing job to test the printer.

4.2.1. Printer Cartridge Cleaning

To ensure maximum printer cartridge life, the cartridge should be cleaned every 8 days or 16000 prints, whichever comes first (based on a maximum usage of 2000 prints per day), or if there is a reduction in print quality.

1. The Spit function should always be tried first to improve print quality.
2. If the Spit function doesn't bring the print quality back, then the cartridge should be removed and the inkjets on the bottom of the cartridge should be wiped down with an alcohol wipe (see procedure on [page 53](#)).

4.3. Cutter Adjustment

The cutter depth has been adjusted from the factory and should not need to be adjusted. If you find that mail is not being opened on cutter setting 1 and 2, the cutter can be adjusted.

To adjust the cutter depth:

1. Set the Cut knob to the “**Standard Cut**” position (Figure 4-7). This position should always cut standard mail deep enough to remove the contents but **not cut** any of the contents. This position will be our reference. The other positions will all be adjusted when this is changed.

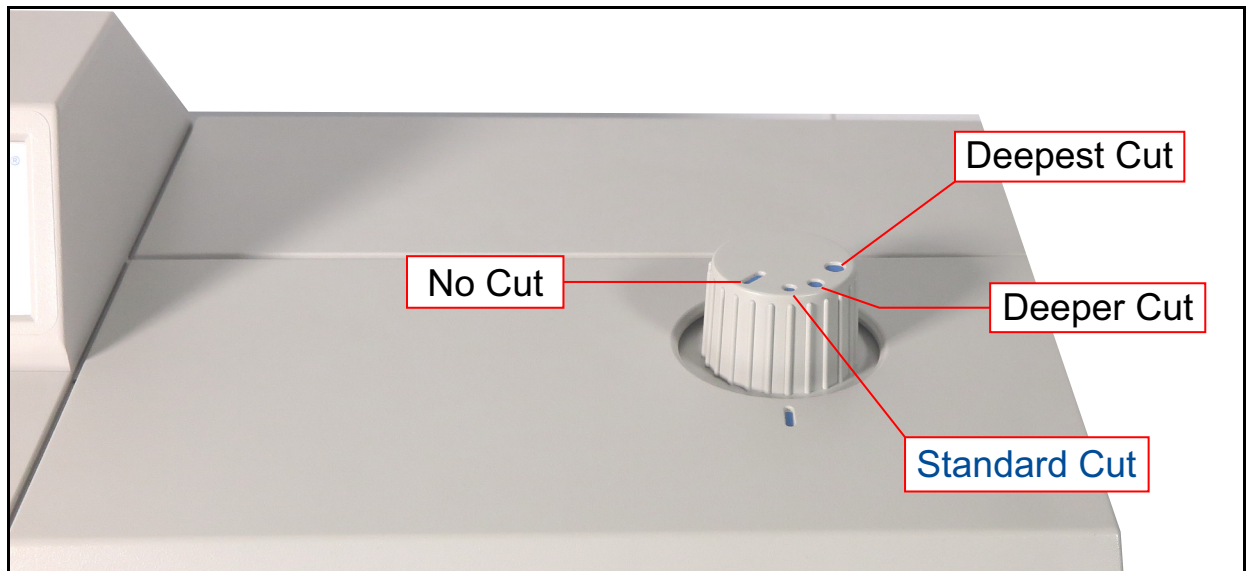

Figure 4-7: Standard Cut position

2. Remove the nip assembly cover (see [page 50](#)).

3. The depth of the cutter can be fine-adjusted by turning the cutter depth screw (Figure 4-8). Using a Phillips screwdriver, turn the screw in 1/4-turn increments; to the right for a deeper cut, or to the left for a shallower cut.

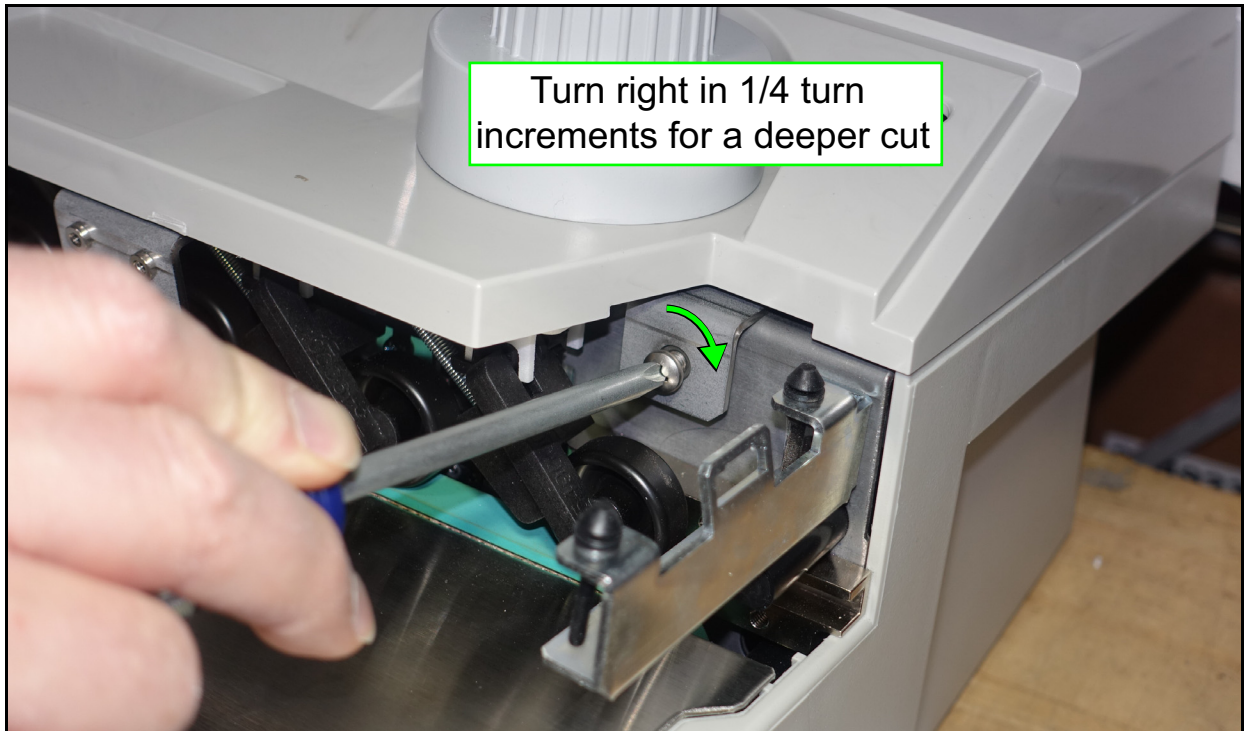

Figure 4-8: Adjusting the cutter depth

4. Replace the cover and run an envelope through to verify if it has been cut.
5. If envelopes are not being cut, repeat steps 1 through 4 as needed. Increments smaller than 1/4 turn can be used to fine tune the cutter.

4.4. Resetting the Circuit Breaker

1. If the OM410 has no display and is plugged in and turned on, check the circuit breaker on the back of the OM410. The breaker shown has been tripped and is open (Figure 4-9).

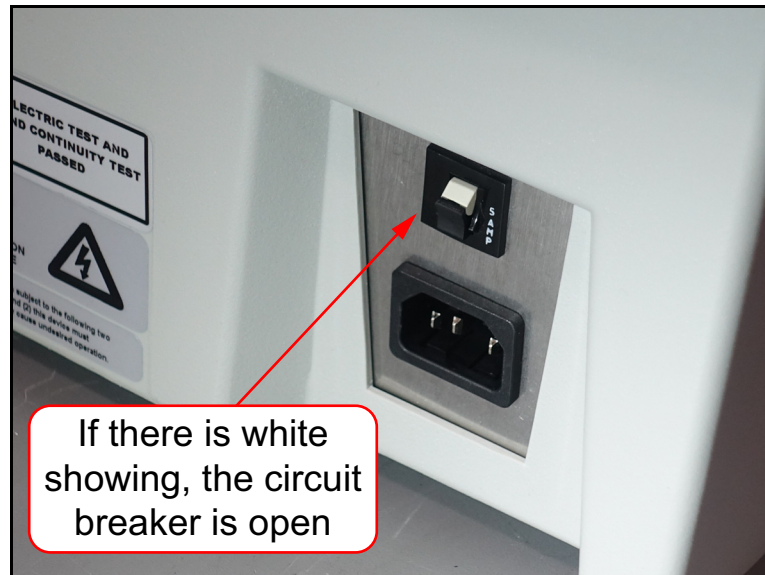

Figure 4-9: Open circuit breaker

2. Unplug the power cord and push the circuit breaker toward the OM410 to close it (Figure 4-10).

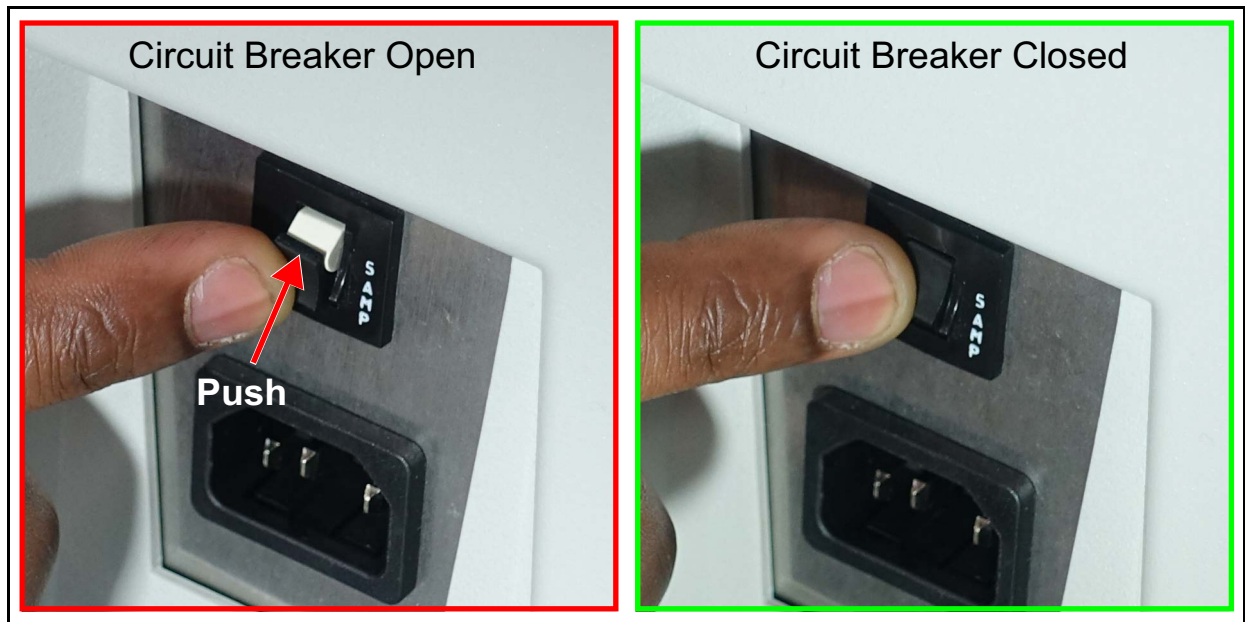

Figure 4-10: Closing the circuit breaker

3. Plug the power cord back into the OM410.
4. Verify the OM410 has a power display and operates normally.
If the circuit breaker pops back out, call OPEX Tech Support to have the OM410 serviced (see [“Contacting OPEX” on page 2](#)).

(This page is intentionally blank)

5. User Replaceable Parts

5.1. Overview 62

5.1. Overview

The parts on the following pages can be replaced by the user. If you're viewing the electronic version of the manual on a tablet, tap the circle pointing to the part to jump to the page the part details are on (Figure 5-1).

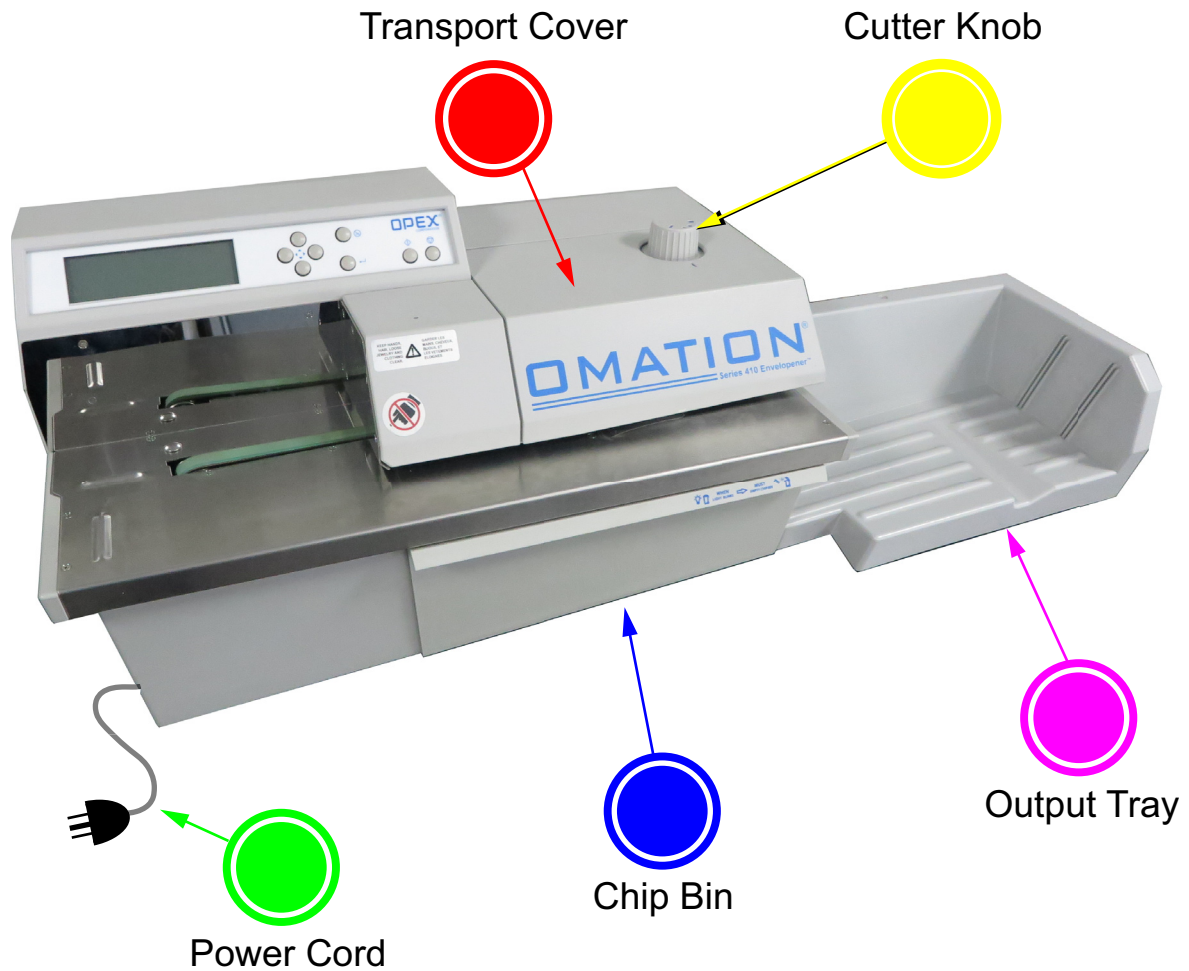

Figure 5-1: User Replaceable Parts

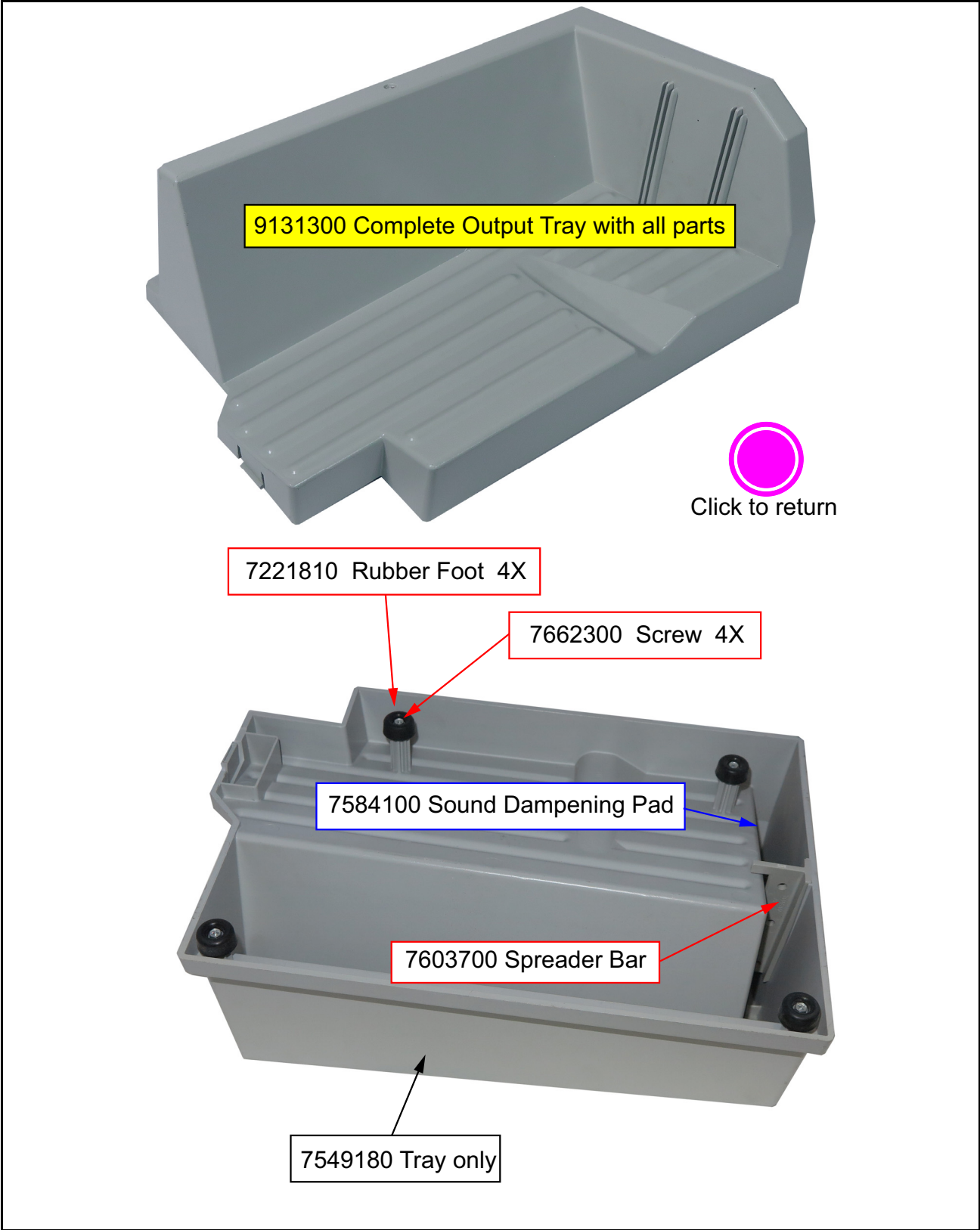

Figure 5-2: Output Tray Assembly

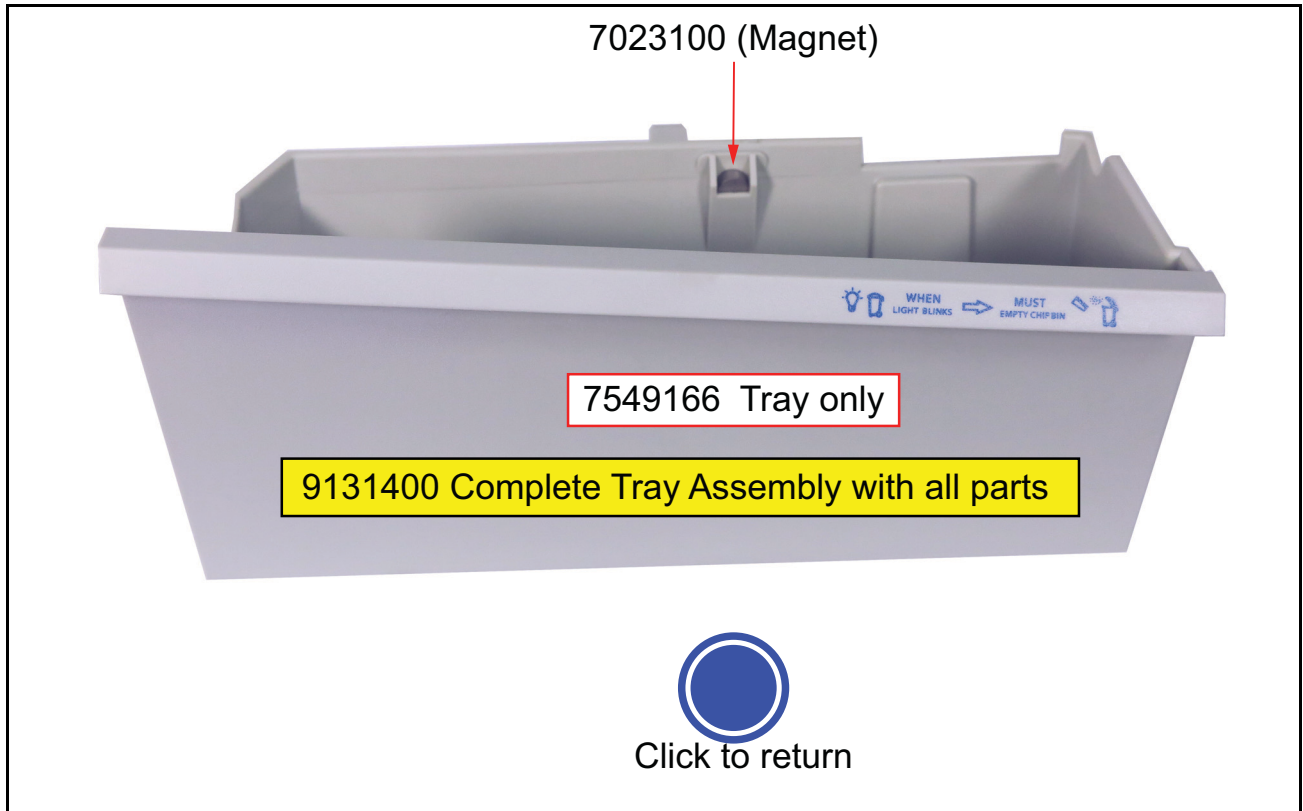

Figure 5-3: Chip Bin Tray Assembly



Figure 5-4: 3387500 Printer Cartridge (under transport cover)



Figure 5-5: 8067050 Cutter Depth Knob



Figure 5-6: 9270940 Transport Cover

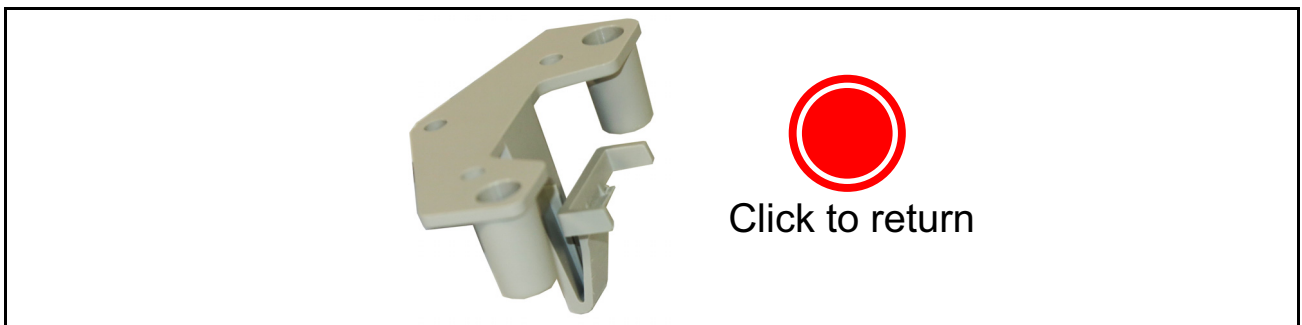

Figure 5-7: 8069225 Transport Cover Latch (under transport cover)

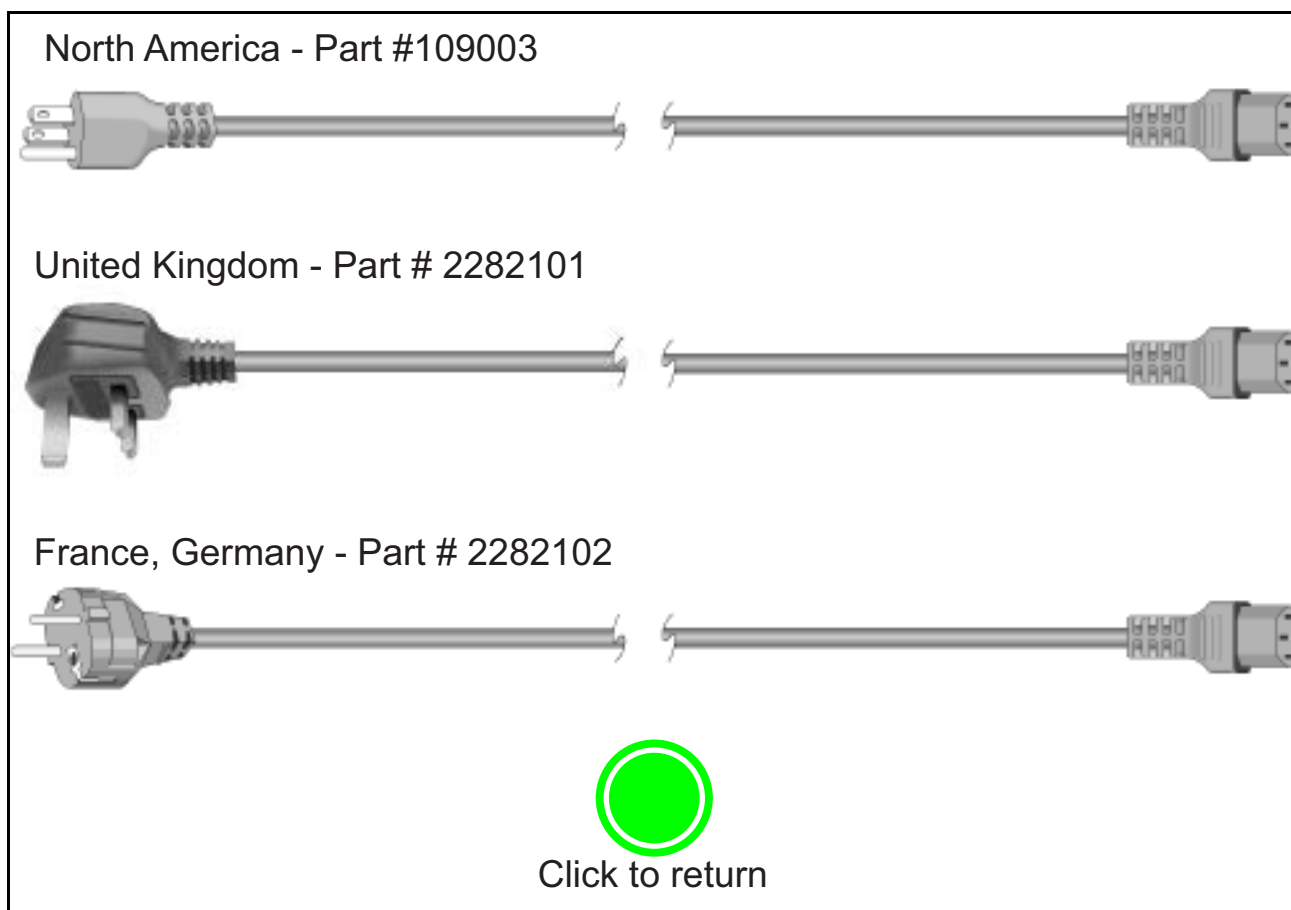

Figure 5-8: AC Power Cords

Table 5-1: Additional Power Cords

Country	Part Number
Australia	# 109008
Denmark	# 109015
India, South Africa	# 109016
Switzerland	# 109018
Italy	# 109019
Japan	# 2952200

G. Glossary

OMATION® Series 410™

Operator Manual

G.1. List of Terms

This is an alphabetical list of terms used in OM410 manuals.

Cam - A rotating wheel with the axle not in the center, transforming rotary motion into linear motion.

Chip bin - Collects cuttings discharged from the cutter.

Circuit breaker - A device that acts as a fuse, but can be reset by pressing it.

Cutter depth knob - Knob to set the depth of cut.

Denatured alcohol - A type of alcohol that can be used for cleaning the outer surfaces of the OM410 that leaves no residue.

Envelope Feed Hopper - The area where the envelopes are stacked to be fed into the retard assembly.

Envelopener - A machine that opens envelopes.

Feed Thumper - A rotating cam that helps to jog the mail for improved feeding.

Feed belt - This belt grabs the bottom envelope, and pulls it into the retard assembly.

Interlock - A safety device that shuts the system down when tripped.

Jam - A problem with the system, typically (but not always) caused by a blockage.

Milling cutter - A cutter that chips away the edges of the envelope small bit at a time, like a circular saw.

Nip arms - Rollers that keep the envelopes firmly pressed against the belt as they move past the cutter.

Operator - The person running the OM410.

Output tray - Collects mail as it leaves the OM410.

Retard Assembly - This separates the mail to one piece at a time as the stack of mail is pulled through this section of the OM410.

Singulate - Separate, or choose one at a time.

About OPEX Corporation

OPEX Corporation is more than a manufacturer of OM410s. We continuously reimagine technology to power the future for our customers.

With an innovative approach, we engineer unique automated solutions that support our customers so they can solve the most pressing business challenges for both today and tomorrow. Our scalable Warehouse, Document, and Mail Automation solutions improve workflow, accelerate change, and drive efficiencies in infrastructure.

We are a family-owned and operated organization with more than 1600 committed employees who innovate, manufacture, install, and service products that are helping transform industry every day. We listen to our customers, respect each other, and work together to help reimagine the future through automated solutions.

At OPEX, we are Next Generation Automation.

OPEX[®]
OMATION[®]
SERIES 410